

# TOP-ACCESS MODULAR HOLDING CABINET OWNERS OPERATORS MANUAL



MT23-6

MANUFACTURED BY:

**CARTER-HOFFMANN**

1551 McCORMICK AVENUE

MUNDELEIN, IL 60060 U.S.A.

PHONE: 847-362-5500

FAX: 847-367-8981

TOLL FREE: 800-323-9793

EMAIL: TECHNICALSERVICE@CARTER-HOFFMANN.COM

**IMPORTANT: DO NOT DISCARD THIS MANUAL**

This manual is considered to be part of the appliance and is to be given to the OWNER or MANAGER, or to the person responsible for training operators of this appliance.

**THIS MANUAL IS TO BE UNDERSTOOD BY ALL PERSONS USING OR INSTALLING THIS APPLIANCE.**

Contact Carter-Hoffmann if you have questions regarding installation, operation or maintenance of this equipment.



READ THIS MANUAL COMPLETELY  
BEFORE OPERATING THIS APPLIANCE

## TABLE OF CONTENTS

SAFETY PRECAUTIONS.....	2
UNPACKING & INSPECTION, FREIGHT DAMAGE.....	3
GROUNDING INSTRUCTIONS.....	3
INSTALLATION & START-UP.....	4
SPECIFICATIONS.....	5
CLEANING.....	6-7
FEATURES & OPERATING CONTROLS.....	7
NORMAL OPERATION .....	8
CONTROLLER PROGRAMMING .....	9
WIRING DIAGRAM AND PARTS LIST.....	10
SERVICE EXPECTATIONS.....	11
WARRANTY STATEMENT.....	12

## SAFETY

Knowledge of proper installation, operation and maintenance procedures is essential to ensure the safe operation of this oven.

1. Always have dry hands prior to using the ON/OFF switch.
2. Turn OFF the ON/OFF switch anytime the cabinet is not in use for extended periods of time.
3. If an electrical shock is felt when touching the cabinet, disconnect the power immediately and call Carter-Hoffmann Technical Service for assistance or service.
4. If the power cord is frayed or the plug damaged, DO NOT PLUG INTO THE ELECTRICAL POWER RECEPTACLE. IF IT IS ALREADY PLUGGED IN, SHUT OFF THE MAIN CIRCUIT BREAKER, LOCATED IN THE BREAKER BOX, THEN DISCONNECT THE PLUG.
5. DISCONNECT THE POWER CORD BEFORE ATTEMPTING ANY REPAIRS TO THE CABINET AND/OR CLEANING THE UNIT. REPAIRS TO THIS UNIT MUST BE PERFORMED BY QUALIFIED PERSONNEL.
6. DO NOT SPRAY WITH WATER HOSE OR SUBMERGE THE CABINET. ELECTRICAL COMPONENTS AND WIRING PRESENT A HIGH SHOCK HAZARD WHEN WET.

## SAFETY PRECAUTIONS



### WARNING: ELECTRIC SHOCK HAZARD

All servicing requiring access to non-insulated components must be performed by qualified service personnel. DO NOT open any access panel that requires the use of tools. Failure to heed this warning may result in severe electric shock.



### CAUTION: ELECTRIC SHOCK HAZARD

Disconnect this appliance from electrical power before performing any maintenance or servicing.



### CAUTION: BURN HAZARD

Exposed metal surfaces can be hot to the touch and may cause burns.

## IMPORTANT SAFETY INSTRUCTIONS

When using electrical appliances basic safety precautions should be adhered to, including the following:

- 1) Operators of this appliance must be familiar with the appliance use, limitations and associated restrictions. Operating instructions must be read and understood by all persons using or installing this appliance.
- 2) This appliance must be grounded. Connect only to properly grounded outlet. See "Grounding Instructions" found on page 3.
- 3) Use this appliance only for its intended use as described in the manual.
  - a. This equipment is specifically designed to hold pre-cooked food at temperature.
  - b. This equipment is intended for use in commercial establishments only.
  - c. This equipment is not designed for industrial or laboratory use.
- 4) Cleanliness of this appliance and accessories is essential to good sanitation.
- 5) DO NOT submerge this appliance in water. This appliance is not jet stream approved. DO NOT direct water jet or steam jet at this appliance, or at any control panel or wiring. DO NOT splash or pour water on, in or over any controls, control panel or wiring. DO NOT use corrosive chemicals or vapors in this appliance.
- 6) DO NOT operate this appliance if it has a damaged cord or plug, if it is not working properly, or if it has been damaged or dropped. Do not immerse cord or plug in water, keep cord away from heated surfaces, and do not let cord hang over edge of table or counter.
- 7) Only qualified service personnel should service this appliance. Contact nearest authorized service facility for examination, repair, or adjustment.
- 8) DO NOT cover or block any openings on the appliance.
- 9) DO NOT store this appliance outdoors. DO NOT use this product near water – for example, near a kitchen sink, in a wet basement, or near a swimming pool, and the like.
- 10) DO NOT use the appliance for storage. DO NOT store flammable or combustible materials in or near the appliance. Never leave anything in a warming cavity when the appliance is not in use.

**SAVE THESE INSTRUCTIONS**

## UNPACKING AND INSPECTION



This appliance should be thoroughly cleaned prior to use.

See the **CLEANING INSTRUCTIONS** on page 6 in this manual.

**NOTE: DO NOT** discard the carton or other packing materials until you have inspected the appliance for hidden damage and checked it for proper operation.

Refer to **FREIGHT DAMAGE CLAIM PROCEDURE** below.

1. Remove the cabinet from shipping carton, ensuring that all packing materials and protective plastic have been removed from the unit.
  2. Inspect all components for completeness and condition.
  3. If any freight damage is present, a freight claim must be filed immediately with the shipping company.
  4. **Freight damage is not covered under warranty.**
  5. Check to insure all components are included: warmer (base, shroud), instruction packet and additional accessories:
    - Polycarbonate pans with lid (2 pans)
    - Ladle (2 ladles)
1. Read operation instructions completely.
  2. Appliance should be thoroughly cleaned before use. See **CLEANING INSTRUCTIONS** on page 6 in this manual.

### FREIGHT DAMAGE PROCEDURE

**NOTE:** For your protection, please note that equipment in this shipment was carefully inspected and packaged by skilled personnel before leaving the factory. Upon acceptance of this shipment, the transportation company assumes full responsibility for its safe delivery.

#### IF SHIPMENT ARRIVES DAMAGED:

1. **VISIBLE LOSS OR DAMAGE:** Be certain that any visible loss or damage is noted on the freight bill or express receipt, and that the note of loss or damage is signed by the delivery person.
2. **FILE CLAIM FOR DAMAGE IMMEDIATELY:** Regardless of the extent of damage. **Contact your dealer immediately.**
3. **CONCEALED DAMAGE:** If damage is unnoticed until the merchandise is unpacked, notify the transportation company or carrier immediately, and then file a "CONCEALED DAMAGE" claim with them. This should be done within fifteen (15) days from the date the delivery was made to you. **Be sure to retain the container for inspection.**

Carter-Hoffmann cannot assume liability for damage or loss incurred in transit, **freight damage is not covered under warranty.** We will, however, at your request, supply you with the necessary documents to support your claim.

### GROUNDING INSTRUCTIONS

This appliance is equipped with a cord having a grounding wire with a grounding plug which must be plugged into an outlet that is properly installed and grounded. In the event of an electrical short circuit, grounding reduces the risk of electric shock by providing an escape wire for the electric current.

**WARNING—Improper use of the grounding can result in a risk of electric shock.** Consult a qualified electrician or service agent if the grounding instructions are not completely understood, or if doubt exists as to whether the appliance is properly grounded.

## INSTALLATION AND START-UP

### IMPORTANT:

Front and back of cabinet must remain clear for access.

Maintain 2" of clearance on each side of cabinet to allow for adequate cooling.

Maintain 5" of clearance above the warmer to allow opening/closing of pan covers.

**NOTE:** The technical content of this manual, including any wiring diagrams, schematics, parts breakdown illustrations and/or adjustment procedures, is **intended for use ONLY by qualified technical personnel.**

1. Check for proper voltage and circuit breaker size. Cabinet requires 120 volt, single phase, 15 Amp circuit. Refer to serial tag on the rear for the electrical requirements for your particular warmer.

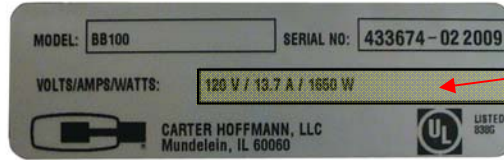

Sample serial tag  
location of electrical specs

2. Ensure receptacle is correctly installed and operating safely. Requires grounded NEMA 5-15R receptacle.
3. Position warmer on table or counter top. Maintain 2" of clearance on each side to allow for adequate cooling.
4. Make sure there is at least 5" of clearance above the unit to allow opening/closing of the pan covers.

### Location

For proper operation and maximum performance, locate the unit in an ambient air temperature of less than 80°F (21°C).

Avoid areas near exhaust fans where there are active air movements.

For safe operation, locate the unit a reasonable distance from combustible walls and materials.

To prevent injury and damage, locate the unit at a proper and safe working height. The location should be level, clean of debris, and strong enough to support the weight of a fully loaded unit.

### Counter-top Mounting

To prevent electrical shock, be sure unit is unplugged from an electrical outlet. If unit has been operated, allow unit to cool before installing. For safety reasons, countertop must be made of a non-combustible material, clean and free of debris.

## ELECTRICAL SPECIFICATIONS

MODEL	PANS	WATTS	VOLTS	AMPS
MT23-6	2	400	120	3.3

Due to the nature of continuing change to the number of configurations we manufacture, your model may not be listed here. Refer to the serial tag on your cabinet for actual electrical specifications.

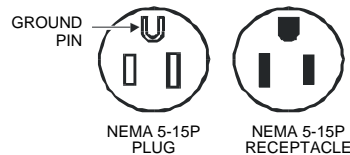

NEMA 5-15P  
PLUG

NEMA 5-15P  
RECEPTACLE

## SPECIFICATIONS

### INTRODUCTION

**Carter-Hoffmann MT Cabinets** are designed to hold pre-cooked food products at temperature. Warmers are available with digital controls with timers. Each pan is independently controlled.



**MT23-6**

Model	Pan Capacity Number 1/3 size Approximately 6.75 x 12.5 x 6 in.	Electrical Requirements	Overall Dimensions			Shipping Weight lbs kg
		Volts / Phase / Hz / Amps / Watts	Height in mm	Depth in mm	Width in mm	
MT23-6	2	120v / 1Ph / 60Hz / 3.3A / 400w	10 254	17.5 445	15.75 400	14 6.4

**CONSTRUCTION...**All stainless steel cabinet construction. Modular design with one controller and one pan cavity per well.

**CABINET MATERIAL...**All stainless steel construction; 20 gauge polished exterior. Each well has an aluminum plate heater.

**LEGS...** Four rubber feet.

**OVERHEAD CLEARANCE...** Minimum 5" required over unit required for opening pan covers.

**CONTROLLERS...** programmable electronic temperature controls with countdown timer and audio/visual alarm. One control for each pan. Each controller allows user to program temperature in one degree increments up to 225°F (107°C) and up to six pre-set times. Timer can be set for up to 9 hours, 59 minutes, in 1 minute increments. Countdown will convert to seconds when less than one minute is left.

**HEATING SYSTEM...** Each well operates on one 200 watt silicone pad heater for each module, 400 watts total. Each well has individual digital controls.

**ELECTRICAL CHARACTERISTICS...** Operates on 120 volts, 60 cycle, single phase, 400 watts, 3.3 amps. Six foot 3 wire rubber cord with 3 prong grounding plug. NEMA 5-15P.

**PERFORMANCE...** Capable of heating to 225°F (107°C). Preheat to 200°F (93°C) in less than 10 minutes. Default set-point for "P1" program is 200°F (93°C)

**ACCESSORIES (included)...**  
Two 1/3 size pans with hinged covers  
Two 5 oz. ladles





**CAUTION:  
ELECTRIC SHOCK  
HAZARD**

Disconnect appliance from electric power before cleaning.



**CAUTION:  
HOT SURFACE**

Exposed surfaces can be hot to the touch and may cause burns. Allow appliance to cool before cleaning.



**IMPORTANT:**

DO NOT spill or pour water into controls, control panel or wiring. Water damage is **not** covered by warranty.

**CLEANING**

**CAUTION:** Unplug cabinet and allow to cool before cleaning.

**Daily Cleaning:**

- 1) Turn off warmer and remove power cord plug from outlet. Allow cabinet to cool.
- 2) Remove pans and clean them in the sink with mild detergent and allow to dry.
- 3) Remove shroud that holds the pans and wash with mild detergent and warm (not hot) water. Wipe clean with clean damp cloth.
- 3) Wipe warmer base with a clean damp towel.
- 4) Rinse by wiping with a clean towel moistened with clean water. Allow to air dry.
- 5) Connect power cord.

**Weekly Cleaning:**

- 1) Turn cabinet off and remove power cord plug from outlet. Allow cabinet to cool.
- 2) Remove pans and pan covers. Clean them in the sink with mild detergent and allow to dry.
- 3) Remove shroud that holds the pans and wash with mild detergent and warm (not hot) water.
- 4) Wipe cabinet and surfaces of warming pads with a clean towel until clean. For heavy soils, use a non-scratch or nylon scouring pad.
- 5) Rinse by wiping with a clean towel moistened with clean water. Allow cabinet to air dry.
- 6) Pans may be cleaned in the sink with mild detergent. Rinse and allow to air dry.
- 7) Connect power cord.



**CAUTION:** Cleansers, detergents, degreasers, sanitizers, or bleaching agents that contain chlorides or phosphates will cause permanent damage to stainless steel products. The damage appears as pits, eruptions, voids, small holes, severe discoloration or dulling of the metal finish.

Water with high chloride content can also damage stainless steel. If unsure of your water quality, we recommend you have it tested. THIS DAMAGE IS PERMANENT, COSTLY TO REPAIR, AND IS NOT COVERED BY THE WARRANTY.

See next page for tips on cleaning stainless steel.

### RECOMMENDED TIPS FOR CLEANING STAINLESS STEEL

<b>Purpose</b>	<b>Frequency</b>	<b>Cleaning Agent</b>	<b>Method of Application</b>
Routine	Daily	Soap, ammonia cleaning detergent and water	Sponge with cloth, rinse with clear water and wipe dry.
Smears/ Fingerprints	As needed	Stainless steel cleaner or similar products	Rub with soft cloth as directed on package. Rub in direction of grain of stainless steel. Do not use on vinyl trim.
Stubborn spots and stains	Daily as needed	Any chloride-free or phosphate-free cleaner	Apply with damp sponge or cloth. Rub in direction of grain of stainless steel. Rinse thoroughly, especially if cleaner contains chlorine bleach; do not use on vinyl trim.
Hard water spots	Daily as needed	Vinegar	Swab with cloth. Rinse with water and wipe dry.

### FEATURES & OPERATING CONTROLS

#### DIGITAL CONTROLS

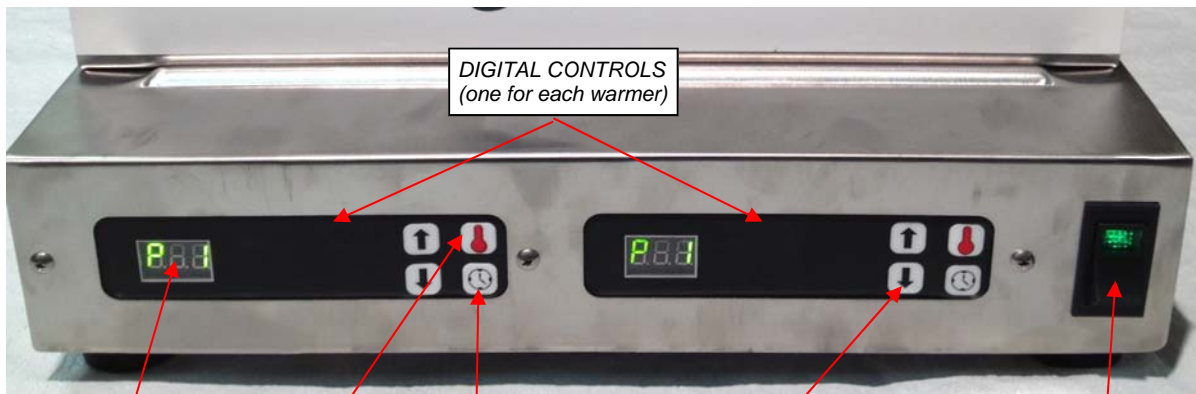

DIGITAL READOUT

TEMP KEY

TIME KEY

INCREASE & DECREASE KEYS

ON/OFF SWITCH

## NORMAL OPERATION

 Temperature

 Typical Temperature

 Module is READY

**NOTE:** Timer cannot be started until the warmer is pre-heated.

**NOTE:** Press and release the TEMP  key to view or verify a cavity Set-point. Cavity set-point will be displayed briefly. If the cavity set-point needs to be changed, refer to *Programming Instructions* on page 9.

**NOTE:** Program timer defaults to "P1" each time the unit is turned OFF then back ON.

 Typical Time Remaining

**NOTE:** Timer can be cancelled at any time during the cycle by pressing and holding the TIME KEY  for 2 seconds. Digital readout will display currently selected timer (e.g. "P 1").



 Timed Cycle Completed

1. Press the POWER switch, located on the front panel, to ON. Illuminated portion of the switch will glow, indicating power is ON. Pre-heat the cabinet for 20 minutes. When first turned on, digital readout will display "LO" until the cabinet reaches 122°F (50°C).

Cavity temperature set-point range is between 122°F (50°C) & 225°F (107°C).

After the cabinet reaches 122°F (50°C), the digital readout will display the current temperature, until the temperature reaches the set-point. Once the cabinet reaches the set-point, the digital readout will display "P 1". This indicates the cabinet is ready to hold product.

2. Select the desired timer program by pressing the INCREASE / DECREASE arrow keys. The cabinet has six programmable timers ("P 1", "P 2", "P 3", "P 4", "P 5", and "P 6") for each cavity. Different program timers can be used for different parts of the day (Breakfast, Lunch, Dinner) or alternate products.

**NOTE:** To select other timer programs ("P 2" through "P 6"), press the INCREASE KEY  or DECREASE KEY  until the digital readout displays the desired program.

3. After pre-heat, load cooked product into pan(s) and place pan(s) in cavity.

Press the TIME KEY  to start the timer. Refer to *Programming Instructions* to change the programmed time

4. The digital readout will count down, displaying the remaining time. The digital readout is displayed in hours and minutes until the time remaining is less than one minute. Once the time remaining is less than one minute, the digital readout counts down in seconds.
5. At the end of the timed cycle, the digital readout will flash "000" and an alarm will sound until the TIME KEY is pressed.
6. The digital readout will display the currently selected timer (e.g. "P 1"), indicating that the cabinet is ready to hold product.
7. At the end of the day or serving period, press POWER switch to OFF. Allow warmer to cool.
8. Remove product pan from cavity. Discard any unused food portions and wash pan in warm soapy water. Rinse and allow to dry.
9. Follow cleaning instructions for cabinet on page 6.

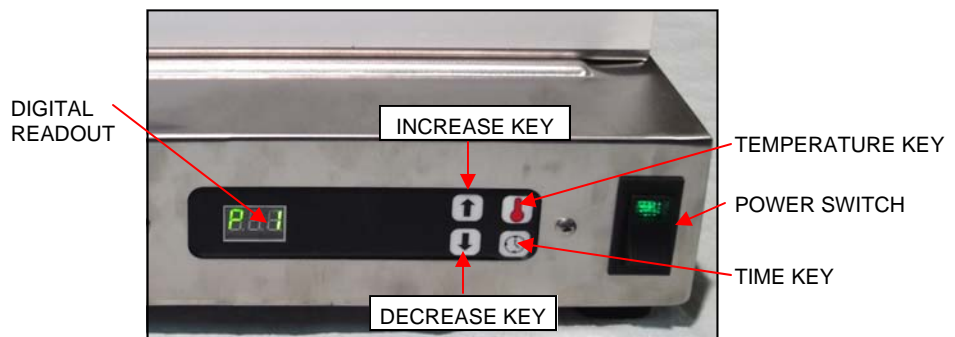



## DIGITAL CONTROLLER PROGRAMMING

**To enter into program mode, display must be in operating mode and not in a timing cycle .**

**NOTE:** Each well can be programmed individually.

### NOTE:

"P1" must be displayed before temperature scale can be changed. If "P1" is not displayed, press ARROW KEY to display "P1."

TEMPERATURE SETPOINT RANGE:

122°F - 225°F  
(50°C - 107°C)

"P1" TEMPERATURE DEFAULT SETPOINT:  
200°F(93°C)

TIMER RANGE:





1 minute to 9 hours, 59 minutes

**NOTE:** While in the program mode, if no key is pressed for 10 seconds, any changes will be saved and the control returns to normal operation mode.







### NOTE:

The technical content of this manual, including any wiring diagrams, schematics, parts breakdown illustrations and/or adjustment procedures, is intended for use **ONLY** by **qualified technical personnel**.

### PROGRAM TEMPERATURE SETPOINT

1. Press and hold the TEMP KEY  until display flashes.
2. Press INCREASE KEY  or the DECREASE KEY  to raise or lower temperature or time set-point. Each time the key is pressed, set-point is changed by 1°.
3. Press TEMP KEY  to save changes

### PROGRAM TIMERS (P1 through P6)

1. Press and hold TIME KEY  until display flashes.
2. Press INCREASE KEY  or the DECREASE KEY  to raise or lower time set-point. Each time the key is pressed, set-point is changed by one minute. Hold the key to scroll faster.
3. Press the TIME KEY  to save changes and return to "P 1".
4. To program timers "P 2" through "P 6":
5. Press INCREASE KEY  or DECREASE KEY  to select desired timer program number ("P 2" thru "P 6").
6. Repeat steps 1 through 3 above for each program.

### TO CANCEL TIMER

Press and hold TIME KEY  for 2 seconds.

### TO CHANGE THE TEMPERATURE SCALE

Press the TEMP KEY  until the temperature starts flashing. Then, press both the up and down arrow buttons (together) until 'F' (Fahrenheit) is displayed.

Press the up or down arrow keys to toggle between °C and °F.

Once selected, press the  TEMP KEY to save and exit.

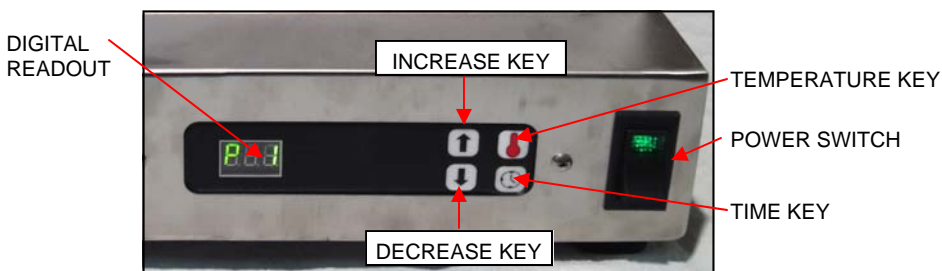

## WIRING DIAGRAM AND PARTS LIST

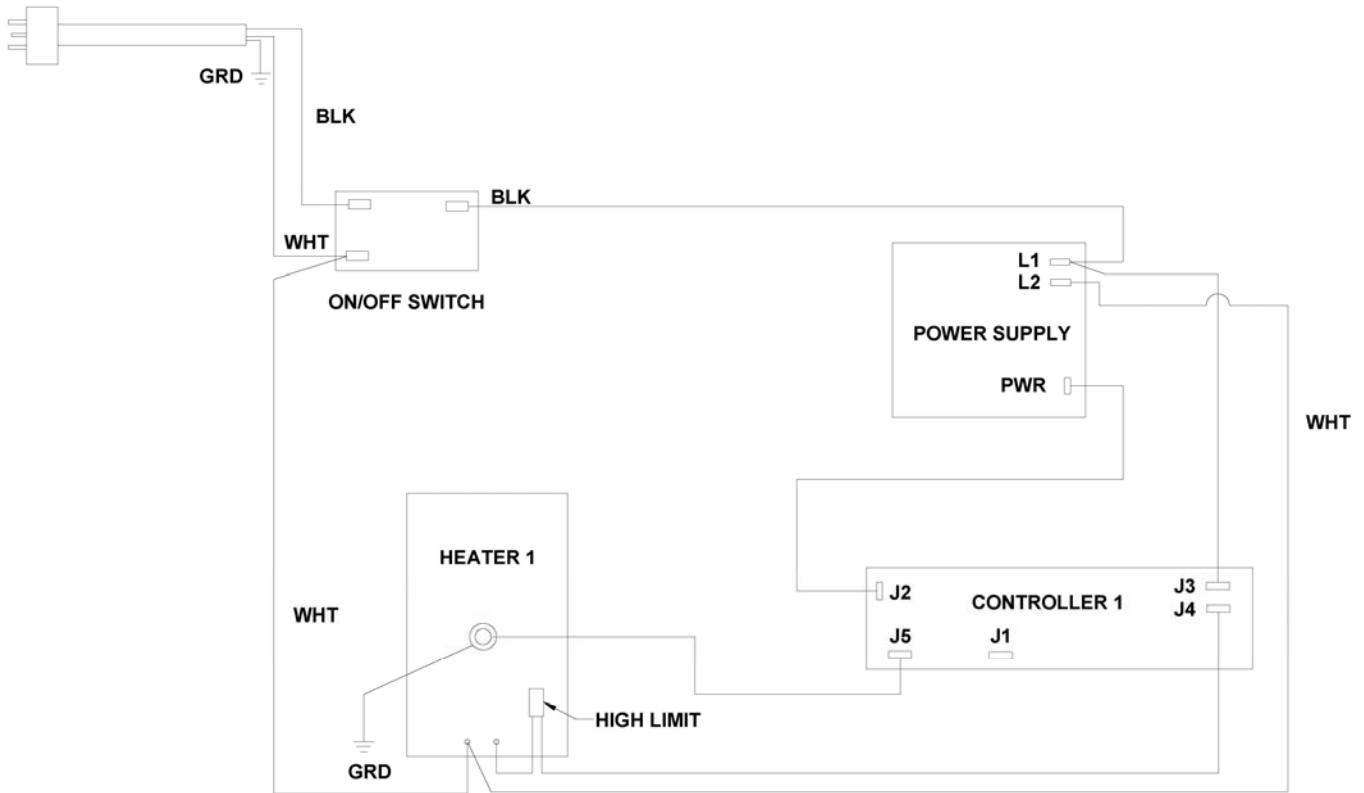

### MT23-6 120V / 400W / 3.3A / 60HZ / 1PH

Part Number	Description
16090-3574	Heating element—200 watts
18616-0267	Timer—225°F
18603-9092	Thermister ring 12" RoHS
18616-0268	Power supply RoHS
18600-0076	Hi-limit 248°F, UI2-120C
18602-0160	Rocker switch
18605-0010	16/3 HSJO cord with 5/15 plug
16505-3928	S.S. pan shroud
18314-0001	Amber 1/3 pan 6" deep
18314-0002	Amber 1/3 notched pan lid
18314-0005	4 ounce soup ladle

#### NOTE:

The technical content of this manual, including any wiring diagrams, schematics, parts breakdown illustrations and/or adjustment procedures, is intended for use **ONLY by qualified technical personnel.**

## SERVICE EXPECTATIONS

### Service Philosophy

*For over sixty years, Carter-Hoffmann has earned a reputation for manufacturing rugged and dependable foodservice equipment that permits foodservice professionals serve better food products to more people, and thus, grow their business.*

Our goal is not only to provide the best food service equipment for the price, but also to back it up with after-sale service that is responsive, fast, efficient and professional. Carter-Hoffmann products are innovative and efficient. They are easy to use, easy to clean and easy to maintain. Although the products are quite reliable, they are also designed to be easy to repair when necessary.

We believe that a malfunction to a Carter-Hoffmann product should cause as little inconvenience to the customer as possible. Our goal is to provide the same day service or within 24 hours and strive to fix it the first time. We are dedicated to making every aspect of our customer service the standard by which others are judged.

### End-User Responsibilities

**While we all strive to serve our mutual customers as well as possible, we remind the end-user (and their employees) that they also have some responsibilities.**

1. All shipping damage must be noted on the freight bill when the shipment is received. Any freight damages must be collected from the Freight Company, NOT Carter-Hoffmann.
2. The end-user should be advised beforehand to carefully unpack and inspect all products when they are received BEFORE SIGNING THE SHIPPER'S RECEIPT OF DELIVERY.
3. The end-user must provide a safe, dry, level surface for the equipment to be placed upon.
4. The end-user must provide the proper electrical supply. All in-wall electrical modifications are to be completed by a licensed electrician. All building modifications are the responsibility of the end user. Specification literature changes frequently, please verify proper installation is possible.
5. The end-user must operate, clean and maintain the equipment in accordance with the procedures described in this Operation Manual.
6. Carter-Hoffmann is NOT responsible for any loss of the customer's income, loss of food product, extra labor charges, or any other incidental or consequential costs as a result of the malfunction of our product.
7. The end-user shall allow for on-premises repair of the equipment to be completed at a mutually convenient place and time.

### Warranty Service

1. Warranty service is to be **initiated** by authorized Carter-Hoffmann personnel only, please call Carter-Hoffmann directly and we will take care of everything. Have your store number and the serial number of the warmer handy. The serial number can be found on the rear of the warmer.
2. The service provider is **NOT** authorized to change or extend any of the terms or conditions of our warranty.
3. Initial freight damage is **NOT** covered by the product warranty.

### Confidentially

1. The end user and all his employees and sub-agents shall protect and keep confidential Carter-Hoffmann's proprietary designs, information, and knowledge.
2. All literature and informational materials provided by Carter-Hoffmann are to be considered confidential; they remain Carter-Hoffmann's property; and are not to be reproduced without our prior approval

#### **NOTE:**

The technical content of this manual, including any wiring diagrams, schematics, parts breakdown illustrations and/or adjustment procedures, is intended for use **ONLY by qualified technical personnel.**

### ***Carter-Hoffmann Warranty:***

*Carter-Hoffmann ("CARTER-HOFFMANN") warrants to the initial purchaser of its standard Carter Line Products that CARTER-HOFFMANN will, at its option, repair or replace, during the warranty period set forth below, any part of such products made necessary due to a defect in material or workmanship which is present when the product leaves its factory and which manifests itself during the warranty period under normal use and service.*

*This warranty applies only to original equipment owned and possessed by the initial purchaser and the warranty period begins on the date of original shipment from the CARTER-HOFFMANN factory and extends as follows: **to component parts and labor for 12 months.***

*Repair or replacements under this warranty will be performed, unless otherwise authorized in writing by CARTER-HOFFMANN, at its factory. All parts or components to be repaired or replaced under this warranty are to be shipped prepaid to CARTER-HOFFMANN, with reimbursement credit for such part or component to be given if found by CARTER-HOFFMANN to be defective.*

*CARTER-HOFFMANN neither makes nor assumes and does not authorize any other person to make or assume any obligation or liability in connection with its products other than that covered in this warranty. This warranty applies only within the continental United States and Canada. In Alaska and Hawaii, this warranty applies only to and is limited to the supply of replacement parts.*

### ***Warranty Exclusions and Limitations:***

*Any implied warranty of merchantability or fitness for a particular purpose is hereby specifically disclaimed by CARTER-HOFFMANN. There are no warranties, expressed or implied, which extend beyond the description on the face hereof. This warranty does not cover and CARTER-HOFFMANN shall not under any circumstances be liable for any incidental, consequential or other damages (such as injury to persons or property, loss of time, inconvenience, loss of business or profits, or other matters not specifically covered) arising in connection with the use of, inability to use, or failure of these products.*

***Specifications are subject to change through product improvement and innovation.***

#### ***Carter-Hoffmann***

**1551 McCormick Ave.**

**Mundelein, Illinois, 60060 USA**

**Phone: 847-362-5500 Toll free: 800-323-9793 Fax: 847-367-8981**

**Sales and Marketing E-mail: [sales@carter-hoffmann.com](mailto:sales@carter-hoffmann.com)**

**Service E-mail: [technicalservice@carter-hoffmann.com](mailto:technicalservice@carter-hoffmann.com)**

**Company Website: [www.carter-hoffmann.com](http://www.carter-hoffmann.com)**

***CFESA*** Proud Member

 **NAFEM**  
North American Association of  
Food Equipment Manufacturers