

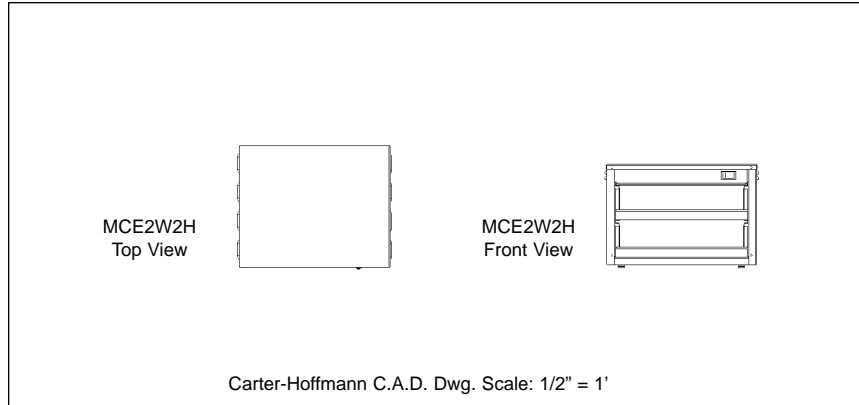

## MCE Series MODULAR HOLDING CABINETS (for 1/3 Size Pans with Handles)



Model Number	Pan Capacity* 1/3 H Approximately 6 <sup>3</sup> / <sub>4</sub> x 12 <sup>1</sup> / <sub>2</sub> x 2 <sup>1</sup> / <sub>2</sub>	Pan Cavity Size		Overall Dimensions						Shipping Weight	
		Height (in)	Width (in)	Height		Depth		Width		lbs	kg
				in	mm	in	mm	in	mm		
MCE2W1H	2	2 <sup>1</sup> / <sub>2</sub>	14	8 <sup>5</sup> / <sub>8</sub>	219	15 <sup>1</sup> / <sub>4</sub>	387	18 <sup>3</sup> / <sub>4</sub>	476	42	19
MCE2W2H	4	2 <sup>1</sup> / <sub>2</sub>	14	11 <sup>3</sup> / <sub>4</sub>	298	15 <sup>1</sup> / <sub>4</sub>	387	18 <sup>3</sup> / <sub>4</sub>	476	55	25
MCE2W3H	6	2 <sup>1</sup> / <sub>2</sub>	14	15	381	15 <sup>1</sup> / <sub>4</sub>	387	18 <sup>3</sup> / <sub>4</sub>	476	72	33
MCE3W1H	3	2 <sup>1</sup> / <sub>2</sub>	14	8 <sup>5</sup> / <sub>8</sub>	219	15 <sup>1</sup> / <sub>4</sub>	387	25 <sup>3</sup> / <sub>4</sub>	654	52	24
MCE3W2H	6	2 <sup>1</sup> / <sub>2</sub>	14	11 <sup>3</sup> / <sub>4</sub>	298	15 <sup>1</sup> / <sub>4</sub>	387	25 <sup>3</sup> / <sub>4</sub>	654	68	31
MCE3W3H	9	2 <sup>1</sup> / <sub>2</sub>	14	15	381	15 <sup>1</sup> / <sub>4</sub>	387	25 <sup>3</sup> / <sub>4</sub>	654	88	40

\*Two pans per shelf

**CONSTRUCTION...**All stainless steel cabinet construction. Four black rubber legs. Riveted and screwed together to form a solid sturdy cabinet.

**CABINET MATERIAL...**All stainless steel cabinet with polished exterior. Aluminum lids are removable for holding drier foods and cleaning.

**DOORLESS PASS-THROUGH DESIGN...** Individually heated shelves accommodate 1/3 size pans, accessible from front and back of cabinet.

**CABINET CAPACITY...** Two per shelf, 1/3 size pans with handles, approximately 6<sup>3</sup>/<sub>4</sub>" x 12<sup>1</sup>/<sub>2</sub>" x 2<sup>1</sup>/<sub>2</sub>" deep. Pass-thru design for access from front and back.

**LIDS...** Fully integrated aluminum lids; removable, without tools, for easy cleaning or holding uncovered food products. Lids in place provide seals for pans containing moisture-sensitive food products.

**CONTROLS...** Electronic temperature controls with countdown timer and audio/visual alarm. Controls allow user to program temperature in one degree increments up to 225°F (108°C). Each time can be set for up to 9 hours, 59 minutes, in one minute increments. Countdown converts to seconds when less than one minute is left. On/off rocker switch.

**HEATING SYSTEM...** Individually heated shelves. One 150 watt tubular heater and black hard coat aluminum plate for each shelf. Direct heat transfer from shelf to food pans.

**ELECTRICAL CHARACTERISTICS...** Operates on 120 volts, 60 cycle, single phase. Six foot 3 wire rubber cord with 3 prong grounding plug. NEMA 5-15P.

MODEL	WATTS	VOLTS	AMPS
MCE2W1H	150	120	1.3
MCE3W1H	150	120	1.3
MCE2W2H	300	120	2.5
MCE3W2H	300	120	2.5
MCE2W3H	450	120	3.8
MCE3W3H	450	120	3.8

**PERFORMANCE...** Capable of heating to 225°F (108°C). Preheat to 160°F (71°C) in less than 10 minutes.

**OPTIONS & ACCESSORIES...**  
1/3 size pans with handles

Specifications subject to change through product improvement & innovation.

**CARTER-HOFFMANN**  
1551 McCormick Ave., Mundelein, IL 60060  
(847) 362-5500 • (800) 323-9793 • Fax (847) 367-8981  
[www.carter-hoffmann.com](http://www.carter-hoffmann.com)

# FEATURES & BENEFITS

1551 McCormick Avenue, Mundelein, Illinois 60060  
Tel. (847)362-5500 • (800)323-9793 • Fax (847)367-8981  
www.carter-hoffmann.com



## MODULAR HOLDING CABINET

*Since 1947, Foodservice Equipment That Delivers!*

### HASSLE-FREE COUNTER-TOP HOLDING

Doorless  
Water-free  
Simple controls  
Space-saving counter-top design

**LIGHTWEIGHT & MODULAR...** For adaptability to a wide range of uses and a variety of spaces.

**PASS-THRU DESIGN...** Easy access products from either side.

**UNIVERSAL HOLDING CAPABILITY...** Unique design allows for a variety of holding environments. Hold moisture-sensitive foods and uncovered foods in the same cabinet.



MCE2W2H

**ALL STAINLESS STEEL CABINET WITH NO MOVING PARTS...** For durability and easy cleaning.



**REMOVABLE FOOD COVERS...** Durable aluminum covers seal in moisture and keep moisture-sensitive food fresh. Removable without tools for uncovered holding and easy cleaning.



**EFFICIENT HEATING...** Individually heated shelves keep food warm via direct contact with food pans.

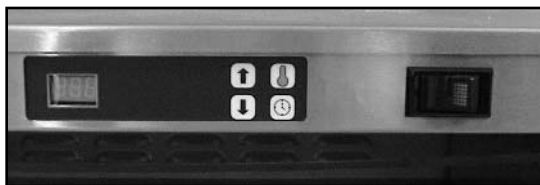

**INDIVIDUAL CONTROLS FOR EACH COMPARTMENT...** Allows the user full control of food temperatures and holding time for each pan for optimum quality. Individual compartments also eliminate flavor transfer among held foods. Audible alarm signals the end of hold cycle.

### MODULAR FOOD HOLDING BENEFITS...

Maintain quality, consistency and freshness of food  
Improve food safety  
Increase efficiency and improve speed and quality of service  
Reduce food waste and ensure constant availability of product  
Lower training costs, simplify staff training and supervision  
Allows more flexible holding options for greater menu variety