

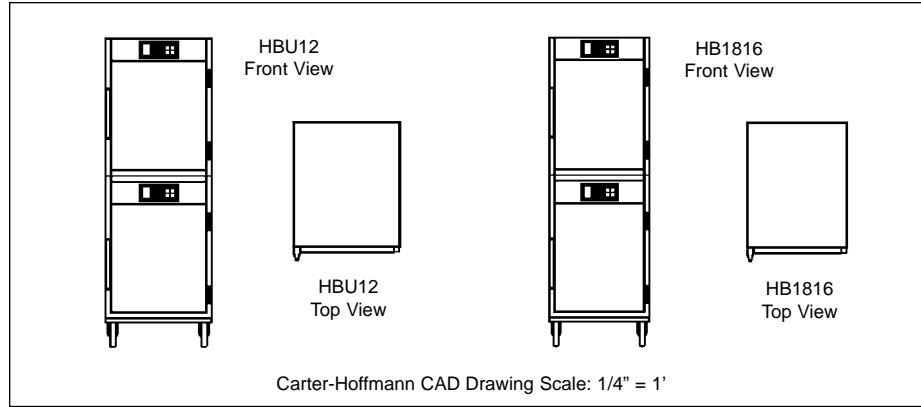

Logic8 Series hotLOGIC HEATED HOLDING CABINETS (with forced air heating system) Two Separate Compartments

CARTER-HOFFMANN
11 FOOD SERVICE EQUIPMENT
HEATED HOLDING CABINETS



Model Number	Tray/Pan Capacity		Inside Working Height		Overall Dimensions						Caster Diameter		Shipping Weight	
	18" x 26"	12" x 20"	in	mm	Height		Depth		Width		in	mm	lbs	kgs
<input type="checkbox"/> HB1816	16	-	22*	559	72 ⁵ / ₈	1845	30 ³ / ₄	781	23 ¹ / ₄	591	5	127	325	148
<input type="checkbox"/> HBU12	12	24	22*	559	72 ⁵ / ₈	1845	30 ³ / ₄	781	26 ⁵ / ₈	676	5	127	325	148

*Inside working height per compartment.

CONSTRUCTION... Completely welded cabinet construction with outer cabinet welded to cabinet liner and bolted to base.

CABINET MATERIAL... All stainless steel construction; 20 gauge polished exterior and 24 gauge interior.

BASE FRAME... 16 gauge stainless steel with all sides turned down for rigidity.

CASTERS... 5" diameter heavy-duty casters with rubber tread. Double ball bearing swivel. Zerk grease fittings. Plate mounted and bolted to base. Two casters fitted with brakes.

INSULATION... High density fiberglass, full 1" thick continuous wrap-around type in top, bottom and sides.

DOORS... Double panel stainless steel; 20 gauge polished exterior and 24 gauge interior. Filled with 1" thick high density fiberglass insulation. Field reversible door swing and gasketless design.

HINGES... Adjustable edgemount hinges with chrome plate finish.

LATCHES... Heavy-duty edgemount latch with magnetic catch on each door.

TRAY RACK ASSEMBLIES... Removable 16 gauge stainless steel tray racks.

HBU12: Removable wire universal slides. Slides fully adjustable at 1 3/4" spacing. Standard spacing at 3 1/2" centers.

HB1816: 18 gauge stainless steel angle slides welded to rack assemblies; fixed spacing at 2 3/4" centers.

CONTROLS... Solid state electronic temperature controller with digital temperature display and temperature alarm. On/off switch and power indicating light. Separate controls for each compartment.

LOW TEMPERATURE ALARM... Equipped with audible temperature alarms; separate alarm for each compartment.

HEATING SYSTEM... Each compartment individually controlled with forced air heating system. Each compartment has one incoloy-sheathed heating element, one fan motor, solid state temperature controller, digital temperature display and on/off switch with power indicating light.

ELECTRICAL CHARACTERISTICS... Operates on 120 volts, 60 cycle, single phase, 2000 watts, 16.7 amps. Six foot 3 wire rubber cord with 3 prong grounding plug. NEMA 5-20P.

PERFORMANCE... Capable of heating to 200° F (94° C). Preheat to 160° F (71° C) in approximately 20 minutes.

ACCESSORIES/OPTIONS...

- Pass-through Doors
- Clear Lexan Doors
- 3" Casters
- 4" Legs in Lieu of Casters
- Alternate Electrical Configurations

SPECIFICATIONS

Specifications subject to change through product improvement & innovation.



CARTER-HOFFMANN
1551 McCormick Ave., Mundelein, IL 60060
(847) 362-5500 • (800) 323-9793 • Fax (847) 367-8981
www.carter-hoffmann.com

Printed in U.S.A. E30 0209
Carter-Hoffmann is a trademark
of Carter-Hoffmann LLC

FEATURES & BENEFITS

1551 McCormick Avenue, Mundelein, Illinois 60060
Tel. (847)362-5500 • (800)323-9793 • Fax (847)367-8981
www.carter-hoffmann.com



Logic8 Series hotLOGIC HEATED HOLDING CABINETS Two Separate Compartments

Since 1947, Foodservice Equipment That Delivers!

HIGH PERFORMANCE CONVECTION HEATER...

Heating system located in top of cabinet with blower for quick heat up and recovery and even heat distribution throughout the cabinet.

STAINLESS STEEL CONSTRUCTION...

all stainless steel interior and exterior for easy sanitation and long lasting appearance.

GASKETLESS DOOR DESIGN WITH EASY GRIP HANDLE...

Ergonomically designed for easy opening. Magnetic catch keeps door positively closed for maximum cabinet temperature maintenance. Gasketless design reduces maintenance.

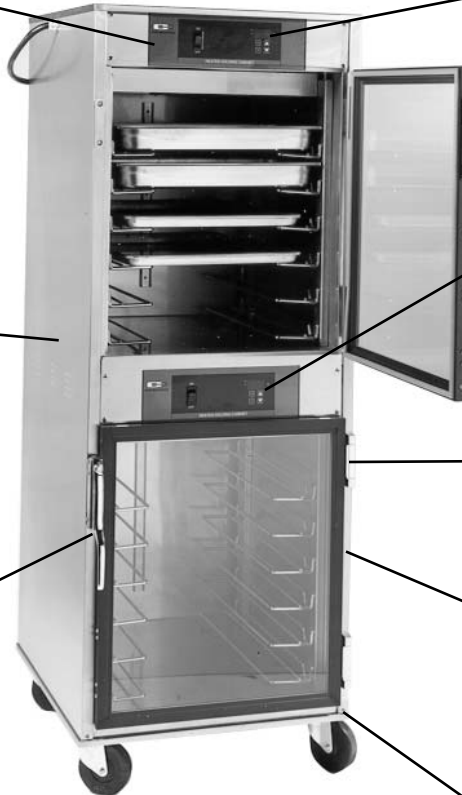

SOLID STATE ELECTRONIC CONTROLLER...

Ensures reliable and consistent cabinet temperature for safe food holding. Digital display for accurate temperature monitoring.

TEMPERATURE SAFETY ALARM...

Alarm alerts the operator if the cabinet temperature drops below a designated level, promoting food safety.

HEAVY-DUTY DOOR HINGES...

Long lasting and durable for frequent opening and closing of doors.

HIGH DENSITY FIBERGLASS INSULATION...

Insulation in cabinet sides, top, bottom, and door for maximum heat retention and efficiency.

STAINLESS STEEL CASTER BASE...

Mobile, for cabinet versatility.

HBU12
(shown with optional clear doors)

REMOVABLE STAINLESS STEEL TRAY RACKS...

Makes routine cleaning simple and quick.



ANSI/NSF 4