



Logix5 Series

hotLOGIX HOLDING & TRANSPORT CABINET

Model HBU18-12J1XM-D

CARTER-HOFFMANN



FOOD SERVICE EQUIPMENT
HEATED HOLDING CABINETS

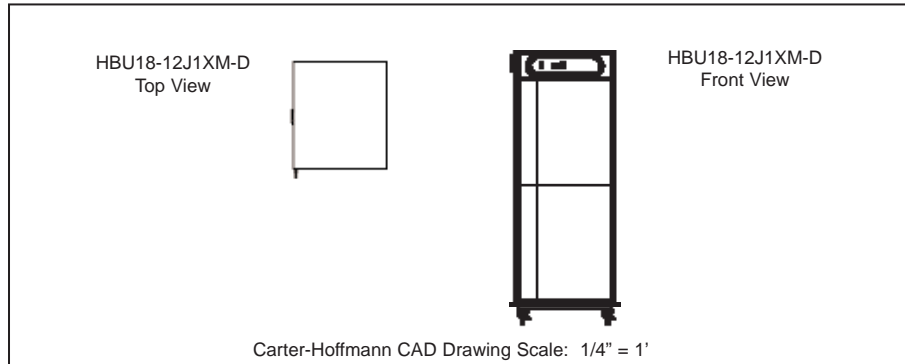

Model Number	Pan/Tray Capacity		Spacing		Inside Working Height		Overall Dimensions			Caster Diameter in mm	Shipping Weight lbs kg					
	12"x20"	18"x26"	in	mm	in	mm	Height in mm	Depth in mm	Width in mm							
HBU18J1XM	24	12	4 1/2	114	57 1/2	1461	76 3/8	1940	36 5/8	930	31 3/8	797	5	127	370	168

CONSTRUCTION...Riveted aluminum double wall cabinet construction. All seams turned in to eliminate raw edges. Four recessed pull grips on sides of cabinet.

CABINET MATERIAL...All aluminum interior and exterior double wall, insulated construction; .063 aluminum exterior with 2V finish.

BASE FRAME...Full depth caster bolsters with perimeter supports welded to bolsters.

BUMPER...Non-marking gray vinyl bumper set in full perimeter, heavy duty 3/16" extruded aluminum frame with reinforced corner "cut-outs."

CASTERS...5" diameter casters with rubber tread (3" casters on HWU5). Four swivel casters. Two casters fitted with brakes.

INSULATION...2" thick high density continuous wrap-around type fiberglass insulation.

DOORS...Double panel Dutch doors; .063 brushed aluminum exterior and stainless steel interior. Filled with 2" thick high density fiberglass insulation. Field-reversible.

HINGES...Adjustable, self-closing, edge mount hinges with chrome plate finish.

GASKET...High temperature magnetic gasket mounted to cabinet.

LATCHES... Exclusive, "posi-slide" latches keep doors securely closed during transport. Side mounted, stainless steel; one for each door.

DOOR HANDLES...Full length integrated door handles.

TRAY RACK ASSEMBLY...Removable stainless steel ducts. 12 pair removable 16 gauge stainless steel universal slides, fully adjustable at 1-1/2" spacing. Standard spacing at 4-1/2" centers.

THERMOMETER...Dial thermometer with remote sensing probe and sensing probe protector.

CONTROLS...Dial temperature control knob and temperature display.

HEATING SYSTEM...Top mounted blower heater for even heat distribution. High impedance protected, internally cooled fan motor. Single cooling fan. Full range thermostat and on/off switch with power indicating light. Energy Star.

ELECTRICAL CHARACTERISTICS... Operates on 120 volts, 60 cycle, single phase, 2100 watts, 17.5 amps. Ten foot rubber cord with 3 prong grounding plug. NEMA 5-20P.

PERFORMANCE...Capable of heating to 200°F (93°C). Preheat to 160°F (71°C) in approximately 25 minutes.

ACCESSORIES/OPTIONS...

- Menu card holder (solid door units only)
- Alternate electrical configurations
- Dutch door/pass-thru-add suffix "-DP"
- Pass-through: add suffix "-P"
- Tempered glass double pane doors-replace "X" with "G" in model number
- Additional slide pairs (universal models)
- Electronic controls

SPECIFICATIONS

Specifications subject to change through product improvement & innovation.

CARTER-HOFFMANN

1551 McCormick Ave., Mundelein, IL 60060
(847) 362-5500 • (800) 323-9793 • Fax (847) 367-8981
www.carter-hoffmann.com



Printed in U.S.A. E80 1110
Carter-Hoffmann is a trademark of Carter-Hoffmann LLC.



Logix5 Series hotLOGIX HOLDING & TRANSPORT CABINET Model HBU18-12J1XM-D

Since 1947, Foodservice Equipment That Delivers!

PRECISION ENGINEERED HEAT DUCT SYSTEM...

Heat duct provides even and efficient heating throughout the entire cabinet for safe and consistent results. Temperature stratification throughout cabinet during preheat and hold is less than 2°F (NSF test protocol). Quick heat recovery. Ducts removable without tools for easy cleaning.

DOORS... Double panel Dutch doors, fully insulated, with magnetic door latch and heavy-duty, self-closing hinges. Full perimeter magnetic gasket attached to cabinet. Side-mounted transport latches for positive closure.

WRAP-AROUND BUMPER... Non-marking gray vinyl set in full perimeter extruded aluminum frame. Floating style is not an extension of the base, but is attached to the base frame; this type of construction absorbs impacts and protects the cart and contents.



SIMPLE DIAL CONTROL... Dial in temperature from 85°F to 200°F. Dial type temperature readout.

INTEGRATED HANDLE... Full length integrated door handle for easy opening and closing of doors. Transport latch for positive closure (not shown).

RECESSED FINGER GRIPS... Finger grips for grasping and moving cabinet. Two on front of side panels and two on back of side panels at comfortable height.

