



FSMC54 & FAMC54 QUICK SERVE™ UNHEATED SOLID TOP UTILITY SERVER

CARTER-HOFFMANN



FOOD SERVICE EQUIPMENT
CAFETERIA SERVERS

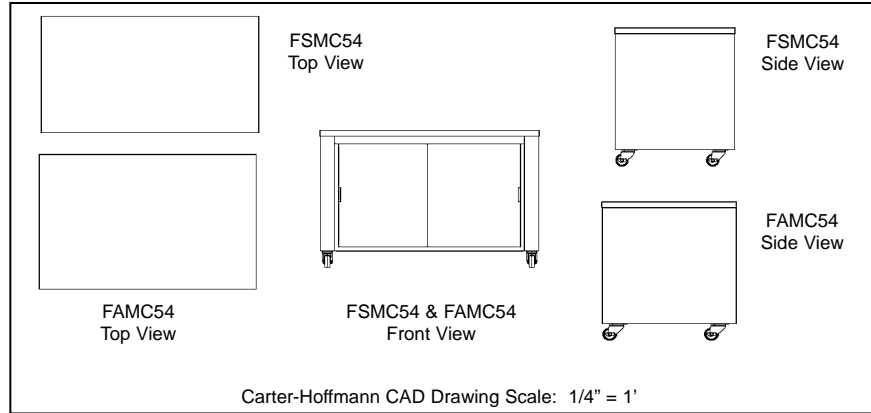

Model Number	Overall Dimensions						Caster Diameter		Shipping Weight	
	Height		Depth		Width		in	mm	lbs	kgs
	in	mm	in	mm	in	mm				
<input type="checkbox"/> FSMC54	36	914	29 1/8	740	54	1372	5	127	530	241
<input type="checkbox"/> FAMC54	36	914	34 1/2	876	54	1372	5	127	550	250

CONSTRUCTION... Completely welded stainless steel construction. Full front, back and end panels. Internally reinforced corners. Polished stainless steel top.

CABINET MATERIAL... 16 gauge stainless steel top reinforced with 14 gauge channels. 18 gauge stainless steel front, back and end panels.

BASE MODULE... Under counter storage holds six top sliding lids (from other system models) on stainless steel tray slides. Tray slides mounted at 30 degree angle for easy access. Double panel stainless steel sliding doors are removable without tools. Bottom track also removable for cleaning.

STYLING... Standard styling is all polished stainless steel.

INTERLOCKS... Quick action finger operated positive latch system aligns and locks multiple units in place to form serving line.

CASTERS... 5" diameter heavy-duty swivel casters with rubber tread. Plate mounted and bolted to frame. All casters fitted with brakes.

ACCESSORIES/OPTIONS...

- Stainless Steel Tray Shelf with Drop-down Brackets
- Stainless Steel Drop-Down End Shelf
- Wire Baskets - Specify Type
- Divided Wire French Fry Basket
- 2-Stack Aluminum Basket Dolly
- Vinyl or High Pressure Laminate Styling
- Elementary Height (Note: Basket Capacity is Reduced)

SPECIFICATIONS

Specifications subject to change through product improvement & innovation.

CARTER-HOFFMANN

1551 McCormick Ave., Mundelein, IL 60060
Tel (847) 362-5500 • (800) 323-9793 • Fax (847) 367-8981
www.carter-hoffmann.com



Printed in U.S.A. 160 1207
Carter-Hoffmann is a registered trademark.

FEATURES & BENEFITS

1551 McCormick Avenue, Mundelein, Illinois 60060
Tel. (847)362-5500 • (800)323-9793 • Fax (847)367-8981
www.carter-hoffmann.com



FSMC54 & FAMC54 QUICK SERVE™ UNHEATED SOLID TOP UTILITY SERVER for pre-packaged food

Since 1947, Foodservice Equipment That Delivers!

STAINLESS STEEL CONSTRUCTION...

Stainless steel interior and exterior for easy sanitation and long lasting clean appearance.

SELF SERVICE DESIGN...

Speeds up service and saves labor because kids serve themselves. Ample space for chip racks and other free-standing merchandising displays

EASY ROLLING ALL

SWIVEL CASTERS... 5" diameter industrial grade casters with rubber tread for easy maneuvering and maximum load strength. All casters with brakes.



COMPLETELY MODULAR... All carts can be used as individual serving units or integrated into straight line and scramble serving lines. Quick action finger operated positive latches easily connect serving units together.

ENCLOSED STORAGE BASE... Holds six top sliding lids on stainless steel slides mounted at 30 degree angle for easy access. Double panel sliding doors and bottom are removable for cleaning.

MANY ACCESSORIES AVAILABLE... A variety of vinyls and high pressure laminates are available for styling to match decor. Additional accessories and base modules can be supplied to increase the flexibility and operator efficiency of one unit or a complete line-up.

