



# FSHR68 QUICK SERVE™ HEATED/REFRIGERATED MOBILE MODULAR SERVER for pre-packaged food

CARTER-HOFFMANN



FOOD SERVICE EQUIPMENT  
CAFETERIA SERVERS

# SPECIFICATIONS

Printed in U.S.A. 152 0608  
Carter-Hoffmann is a trademark  
of Carter-Hoffmann Corp.

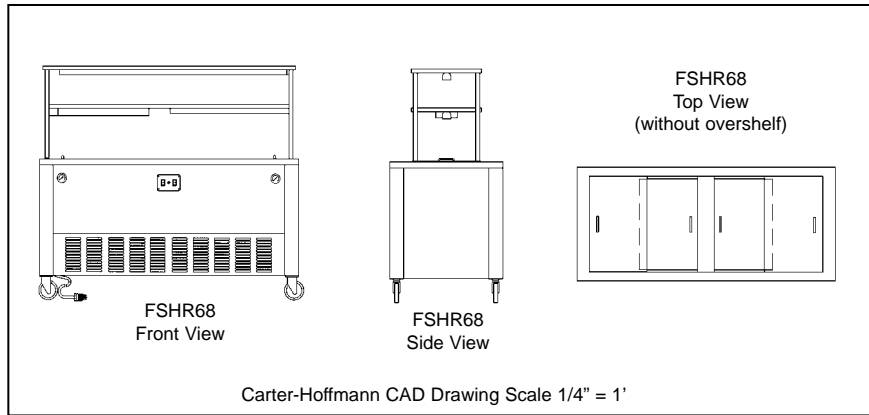

Model Number	Basket Capacity		Overall Dimensions						Caster Diameter		Shipping Weight	
	Each Well		Height**		Depth		Width		in	mm	lbs	kgs
	Type*		in	mm	in	mm	in	mm				
FSHR68	A	B										
	6	12	36	915	29 <sup>1</sup> / <sub>8</sub>	737	68 <sup>1</sup> / <sub>4</sub>	1734	5	127	716	325

\* Basket Types: A-13"x20"x4-9/16"; B-13"x20"x2-1/8"  
\*\* Overshelf adds 24" to overall height.

**CONSTRUCTION...** Completely welded double wall stainless steel construction. Full front, rear and end panels. Polished stainless steel top.

**CABINET MATERIAL...** All stainless steel construction; 18 gauge exterior and interior panels. 16 gauge top.

**STYLING...** Standard styling is all polished stainless steel.

**INTERLOCKS...** Quick action finger operated spring loaded interlock system on each of the bottom corners aligns and locks multiple units in place to form serving line.

**CASTERS...** 5" diameter heavy-duty swivel casters with polyurethane tread. Plate mounted and bolted to frame. All casters fitted with brakes.

**INSULATION...** Well insulated on all sides and bottom with 2" high density fiberglass. Additional insulation provided to seal and isolate heated well from top surface.

**OVERSHELF...** 18 gauge stainless steel double overshelf with 16 gauge x 1" square stainless steel upright supports. Lighted under upper shelf. Lighted/heated on left and lighted on right under lower shelf.

**TOP SLIDING LIDS...** Two sets of 3/4" thick sliding lids with high pressure laminate covering and stainless steel band edging. Removable without tools.

**CONTROLS...** Adjustable range thermostat and power indicating light. Rocker switches for heated & refrigerated sections. Overshelf lights operated with single switch on operator side. Overshelf heater operated with separate switch on heating unit.

**THERMOMETERS...** Dial type with remote sensing bulb and sensing bulb protector. One for heated section and one for refrigerated section.

**HEATED WELL...** Located on operator left. All stainless steel 18 gauge heat well with coved corners. 13<sup>5</sup>/<sub>8</sub>"D x 21<sup>1</sup>/<sub>8</sub>"W x 28<sup>5</sup>/<sub>8</sub>"L.

**REFRIGERATED WELL...** Located on operator right. All stainless steel 18 gauge refrigerated well with coved corners. 13<sup>5</sup>/<sub>8</sub>"D x 21<sup>1</sup>/<sub>8</sub>"W x 28<sup>5</sup>/<sub>8</sub>"L.

**BLOWER HEATING/REFRIGERATION SYSTEM...** 900 watt heating system. Blower refrigeration system with 1/4 H.P. compressor and 300 watt condensation evaporator pan.

**ELECTRICAL CHARACTERISTICS...** 2766 watts, 120/208 volts, 22 amps, 60 Hz, single phase. 10 foot grounded power cord with 120/208 NEMA L14-30 plug located on operator left.

- ACCESSORIES/OPTIONS...**
- Single Tier Unheated Merchandiser
  - Stainless Steel Tray Shelf with Drop-down Brackets
  - Wire Baskets
  - 2-Stack Aluminum Basket Dolly
  - Vinyl or High Pressure Laminate Styling
  - Alternate Caster Sizes & Treads

Specifications subject to change through product improvement & innovation.

## CARTER-HOFFMANN

A Division of Carrier Commercial Refrigeration, Inc.  
1551 McCormick Ave., Mundelein, IL 60060  
(847) 362-5500 • (800) 323-9793 • Fax (847) 367-8981  
[www.carter-hoffmann.com](http://www.carter-hoffmann.com)



# FEATURES & BENEFITS

1551 McCormick Avenue, Mundelein, Illinois 60060  
 Tel. (847)362-5500 • (800)323-9793 • Fax (847)367-8981  
 www.carter-hoffmann.com



## FSHR68 QUICK SERVE™ HEATED/REFRIGERATED MOBILE MODULAR SERVER for pre-packaged food

*Since 1947, Foodservice Equipment That Delivers!*

**STAINLESS STEEL CONSTRUCTION...** 300 series stainless steel interior and exterior for easy sanitation and long lasting clean appearance.

**SELF SERVICE DESIGN...** Speeds up service and saves labor because kids serve themselves. Large capacity wells reduce number of restocking trips.

**TOP SLIDING LIDS...** Keep unit closed and efficiently heating during non-serving times. Easily removed for serving.

**EASY ROLLING ALL SWIVEL CASTERS...** 5" diameter industrial grade casters with polyurethane tread for easy maneuvering and maximum load strength. All casters with brakes.

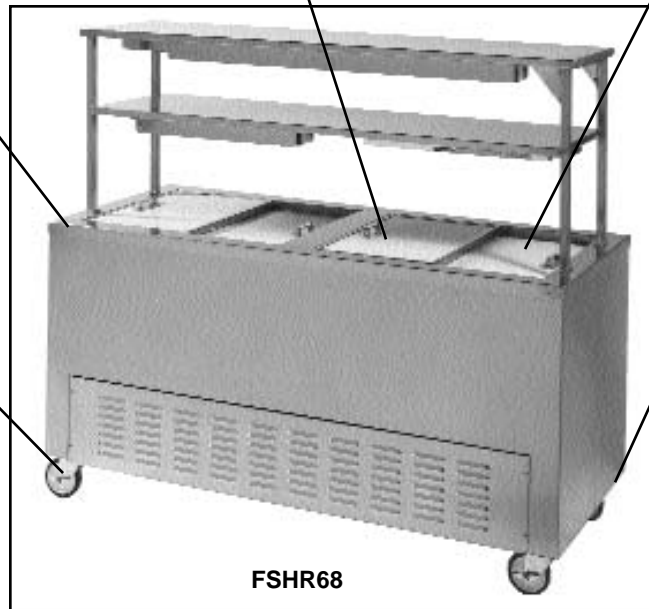

FSHR68

**COMPLETELY MODULAR...** Carts can be used as individual serving units or integrated into straightline and scramble serving lines. Quick action finger operated positive latches easily connect serving units together.

**MANY ACCESSORIES AVAILABLE...** A variety of vinyls and high pressure laminates are available for styling to match decor. Additional accessories and base modules can be supplied to increase the flexibility and operator efficiency of one unit or a complete line-up.

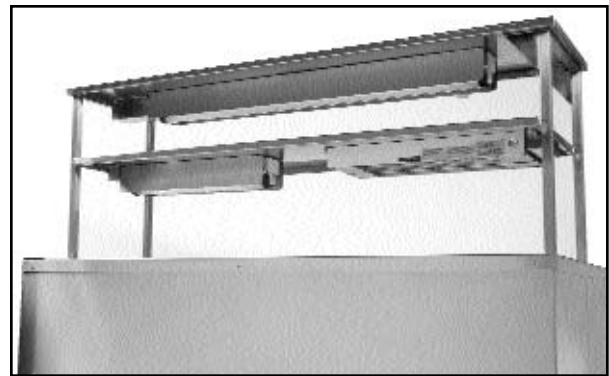

**DOUBLE OVERSHELF...** For added vertical capacity. Lighted under upper shelf. Lighted/heated over heated compartment and lighted over refrigerated compartment.

