

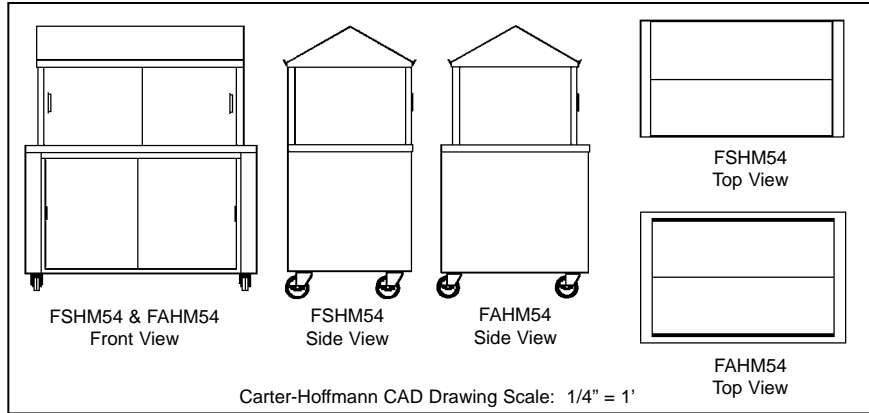

FSHM54 & FAHM54 QUICK SERVE™ HEATED DISPLAY MERCHANDISER for pre-packaged food



SPECIFICATIONS

Model Number	Capacity			Overall Dimensions						Caster Diameter		Shipping Weight	
	Baskets*			Height		Depth		Width		in	mm	lbs	kgs
	A	B	C	in	mm	in	mm	in	mm				
<input type="checkbox"/> FSHM54	10	10	-	64 ¹ / ₄	1632	29 ¹ / ₈	740	54	1372	5	127	585	266
<input type="checkbox"/> FAHM54	-	-	10	64 ¹ / ₄	1632	34 ¹ / ₂	876	54	1372	5	127	605	274

*Basket types: A - 13" x 20" x 4⁹/₁₆"; B - 13" x 20" x 2³/₁₆"; C - 13³/₈" x 25⁷/₈" x 2⁵/₈"

CONSTRUCTION... Completely welded stainless steel construction. Full front, back and end panels. Internally reinforced corners. Polished stainless steel top.

CABINET MATERIAL... 16 gauge stainless steel top reinforced with 14 gauge channels. 18 gauge stainless steel front, back and end panels.

MERCHANDISER CONSTRUCTION... Upright supports constructed of 1 1/2" square 16 gauge stainless steel tubing with intermediate shelf constructed on 7/8" round 16 gauge stainless steel. Sliding doors and end panels are 1/4" thick lexan. Doors are removable without tools. Bottom track removable for cleaning.

BASE MODULE... Under counter storage holds six top sliding lids (from other system models) on stainless steel tray slides. Tray slides mounted at 30 degree angle for easy access. Double panel stainless steel sliding doors are removable without tools. Bottom track also removable for cleaning.

STYLING... Standard styling is all polished stainless steel.

INTERLOCKS... Quick action finger operated positive latch system aligns and locks multiple units in place to form serving line.

CASTERS... 5" diameter heavy-duty swivel casters with rubber tread. Plate mounted and bolted to frame. All casters fitted with brakes.

CONTROLS... Adjustable range thermostat and power indicating light. Controls located inside storage base and accessed through sliding doors.

PERFORMANCE... Capable of heating to a temperature of 190°F (88°C). Pre-heating time to 160°F (71°C) approximately 40 minutes.

HEATING SYSTEM... Patented dual fan convected air heating system with two 200 CFM blower and on/off switch. Components include high limit protection circuit, 900 watt boxed inconel sheathed element. High impedance protected fan motor with self-lubricated bearings. Six 175 watt infra-red heat lamps.

ELECTRICAL CHARACTERISTICS... Operates on 120 volts, 60 cycle, single phase, 2100 watts, 18 amps. Ten foot rubber cord with grounded plug. NEMA 5-30P plug.

- ACCESSORIES/OPTIONS...**
- Stainless Steel Tray Shelf with Drop-down Brackets
 - Stainless Steel Drop-Down End Shelf
 - Wire Baskets - Specify Type
 - Divided Wire French Fry Basket
 - 2-Stack Aluminum Basket Dolly
 - Vinyl or High Pressure Laminate Styling
 - Elementary Height (Note: Basket Capacity is Reduced)

Specifications subject to change through product improvement & innovation.

CARTER-HOFFMANN

1551 McCormick Ave., Mundelein, IL 60060

Tel (847) 362-5500 • (800) 323-9793 • Fax (847) 367-8981

www.carter-hoffmann.com



FEATURES & BENEFITS

1551 McCormick Avenue, Mundelein, Illinois 60060
Tel. (847)362-5500 • (800)323-9793 • Fax (847)367-8981
www.carter-hoffmann.com



FSHM54 & FAHM54 QUICK SERVE™ HEATED DISPLAY MERCHANDISER for pre-packaged food

Since 1947, Foodservice Equipment That Delivers!

STAINLESS STEEL CONSTRUCTION...

Stainless steel interior and exterior for easy sanitation and long lasting clean appearance.

SELF SERVICE DESIGN...

Speeds up service and saves labor because kids serve themselves. Large capacity well reduces number of restocking trips.

TOP SERVING ACCESS...

Solid stainless steel angled top provides additional space for merchandising unheated foods in baskets.



FSHM54

HEATING SYSTEM... 200 CFM blower heater directs warm air across surface of unit for even heating of food on counter. Six overhead infra-red heating lamps keep food warm on the shelf above.

ENCLOSED STORAGE

BASE... Holds six top sliding lids on stainless steel slides mounted at 30 degree angle for easy access. Double panel sliding doors and bottom track are removable for cleaning.

EASY ROLLING ALL SWIVEL

CASTERS... 5" diameter industrial grade casters with rubber tread for easy maneuvering and maximum load strength. All casters with brakes.

COMPLETELY MODULAR... All carts can be used as individual serving units or integrated into straightline and scramble serving lines. Quick action finger operated positive latches easily connect serving units together.

MANY ACCESSORIES AVAILABLE... A variety of vinyls and high pressure laminates are available for styling to match decor. Additional accessories and base modules can be supplied to increase the flexibility and operator efficiency of one unit or a complete line-up.

