



FSH50, FAH50, FSH63 & FAH63 QUICK SERVE™ HEATED MOBILE MODULAR SERVING UNITS for pre-packaged food

CARTER-HOFFMANN



FOOD SERVICE EQUIPMENT
CAFETERIA SERVERS

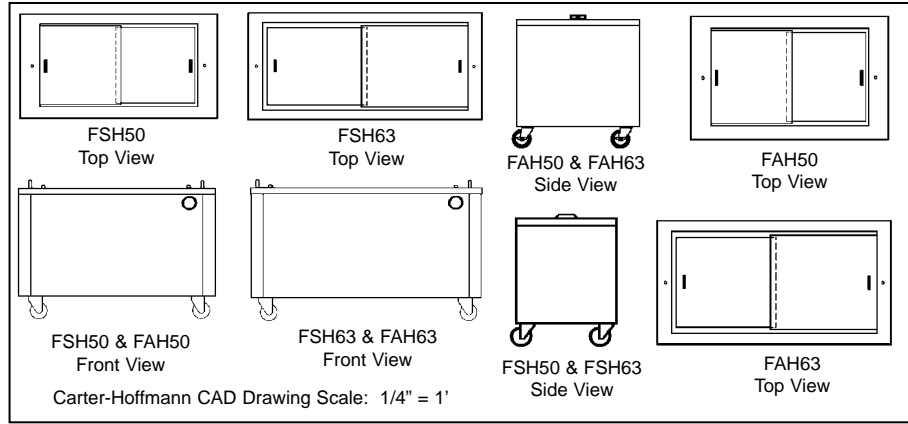

Model Number	Capacity			Overall Dimensions						Caster Diameter		Shipping Weight	
	Baskets*			Height		Depth		Width		in	mm	lbs	kgs
	A	B	C	in	mm	in	mm	in	mm				
<input type="checkbox"/> FSH50	9	21	-	36	914	29 1/8	740	50	1270	5	127	525	239
<input type="checkbox"/> FAH50	-	-	15	36	914	34 1/2	876	50	1270	5	127	545	248
<input type="checkbox"/> FSH63	12	28	-	36	914	29 1/8	740	63	1600	5	127	575	261
<input type="checkbox"/> FAH63	-	-	20	36	914	34 1/2	740	63	1600	5	127	595	270

*Basket types: A - 13" x 20" x 4 9/16"; B - 13" x 20" x 2 3/16"; C - 13 3/8" x 25 7/8" x 2 5/8"

CONSTRUCTION... Completely welded stainless steel construction. Full front, back and end panels. Internally reinforced corners. Polished stainless steel top.

CABINET MATERIAL... 16 gauge stainless steel top reinforced with 14 gauge channels. 18 gauge stainless steel front, back and end panels.

INTERLOCKS... Quick action finger operated positive latch system aligns and locks multiple units in place to form serving line.

CASTERS... 5" diameter heavy-duty swivel casters with rubber tread. Plate mounted and bolted to frame. All casters fitted with brakes.

WELL INSULATION... Insulated on all sides and bottom with 2" high density fiberglass. Additional insulation provided to seal and isolate heated well from top surface.

TOP SLIDING LIDS... 3/4" thick sliding lids with high pressure laminate covering and stainless steel band edging. Removable without tools.

LID LOCKING BAR... Stainless steel locking bar prevents unsupervised opening. Entire assembly removable for easy serving. Locking pins bolted to top of cabinet.

STYLING... Standard styling is all polished stainless steel with laminated top sliding lids.

CONTROLS... Adjustable range thermostat and power indicating light. Controls located behind vented access panel on operator's side.

HEATED WELL... All stainless steel 18 gauge heat well with coved corners; 15 3/4" deep. See chart above for capacities.

PERFORMANCE... Capable of heating to a temperature of 220°F (104°C). Pre-heat time to 180°F (82°C) approximately 20 minutes.

HEATING SYSTEM... Patented dual fan convected air heating system with two 100 CFM blowers and on/off switch. Three 900 watt inconel-sheathed heating elements with high limit protection. Two high impedance protected internally-cooled fan motors with self-lubricated bearings.

ELECTRICAL CHARACTERISTICS... Operates on 120 volts, 60 cycle, single phase, 2800 watts, 23.3 amps. Eight foot rubber cord with grounded plug. NEMA 5-30P plug.

ACCESSORIES/OPTIONS...

- Single Tier Unheated Merchandiser
- Stainless Steel Tray Shelf with Drop-down Brackets
- Stainless Steel Drop-Down End Shelf
- Wire Baskets - Specify Type
- Divided Wire French Fry Basket
- 2-Stack Aluminum Basket Dolly
- Vinyl or High Pressure Laminate Styling
- Elementary Height (Note: Basket Capacity is Reduced)

SPECIFICATIONS

Specifications subject to change through product improvement & innovation.

CARTER-HOFFMANN

1551 McCormick Ave., Mundelein, IL 60060

Tel (847) 362-5500 • (800) 323-9793 • Fax (847) 367-8981

www.carter-hoffmann.com



Printed in U.S.A. 145 1207
Carter-Hoffmann is a registered trademark.

FEATURES & BENEFITS

1551 McCormick Avenue, Mundelein, Illinois 60060
Tel. (847)362-5500 • (800)323-9793 • Fax (847)367-8981
www.carter-hoffmann.com



FSH50, FAH50, FSH63 & FAH63 QUICK SERVE™ HEATED MOBILE MODULAR SERVING UNITS for pre-packaged food

Since 1947, Foodservice Equipment That Delivers!

STAINLESS STEEL CONSTRUCTION...

Stainless steel interior and exterior for easy sanitation and long lasting clean appearance.

SELF SERVICE DESIGN...

Speeds up service and saves labor because kids serve themselves. Large capacity well reduces number of restocking trips.



FAH50
(shown with optional single tier merchandiser
and wire baskets)

PATENTED DUAL FAN HEATING SYSTEM...

Two blowers for fast even heating and recovery. Efficient warm air screen over the top of the well, keeps entire interior warm with the lids open. Dual fan operation ensures food safe temperatures.

TOP SLIDING LIDS WITH LID LOCKING BAR...

Keep unit closed and efficiently heating during non-serving times. Easily removed for serving. Locking bar secures unit during unsupervised times (Not shown).

EASY ROLLING ALL SWIVEL CASTERS...

5" diameter industrial grade casters with rubber tread for easy maneuvering and maximum load strength. All casters with brakes.

COMPLETELY MODULAR...

All carts can be used as individual serving units or integrated into straightline and scramble serving lines. Quick action finger operated positive latches easily connect serving units together.

MANY ACCESSORIES AVAILABLE... A variety of vinyls and high pressure laminates are available for styling to match decor. Additional accessories and base modules can be supplied to increase the flexibility and operator efficiency of one unit or a complete line-up.

