

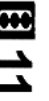

FSFI35 & FAFI35 QUICK SERVE™ REFRIGERATED MOBILE MODULAR FREEZERS for pre-packaged food

CARTER-HOFFMANN



FOOD SERVICE EQUIPMENT
CAFETERIA SERVERS



FSFI35

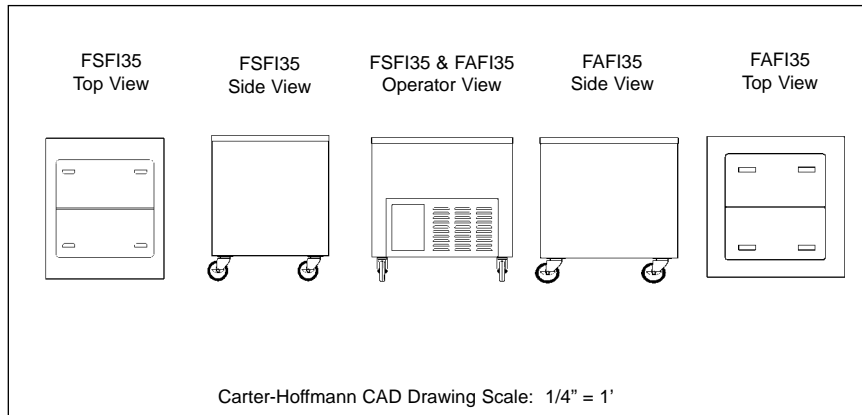

Carter-Hoffmann CAD Drawing Scale: 1/4" = 1'

Model Number	Compartment Size / Capacity		Overall Dimensions						Caster Diameter		Shipping Weight	
			Height		Depth		Width					
	in	cubic feet	in	mm	in	mm	in	mm	in	mm	lbs	kgs
<input type="checkbox"/> FSFI35	20 x 20	4.9	36	914	29 ¹ / ₈	737	35	889	5	127	456	207
<input type="checkbox"/> FAFI35	20 x 20	4.9	36	914	34 ¹ / ₂	876	35	889	5	127	476	216

CONSTRUCTION... Completely welded stainless steel construction. Full front, back and end panels. Internally reinforced corners. Polished stainless steel top. Full length stainless steel vent panel with sliding door to access on/off switch.

CABINET MATERIAL... 16 gauge stainless steel top reinforced with 14 gauge channels. 18 gauge stainless steel front, back and end panels.

INTERLOCKS... Quick action finger operated positive latch system aligns and locks multiple units in place to form serving line.

CASTERS... 5" diameter heavy-duty swivel casters with rubber tread. Plate mounted and bolted to frame. All casters fitted with brakes.

WELL INSULATION... Insulated on all sides with 1" foamed-in place urethane insulation.

COMPARTMENT LIDS... All stainless steel double panel bi-fold hinge design. Easily removed without tools.

LID LOCKING BAR... Stainless steel locking bar prevents unsupervised opening. Entire assembly removable for easy serving. Locking pins bolted to top of cabinet.

FREEZER COMPARTMENT... 18 gauge insulated stainless steel compartment with coved corners. Seamless copper tubing bonded to outside surface of inner wall for maximum cooling. 1/2" diameter stainless steel drain has removable rubber stopper.

STYLING... Standard styling is all polished stainless steel.

PERFORMANCE... Capable of cooling to a temperature of 0°F (-18°C).

REFRIGERATION SYSTEM... Self contained cold wall concealed refrigeration system. Components include on/off switch, air cooled high torque 1/4 H.P. condensing unit with cold wall refrigerated divider evaporator and capillary refrigerant control. CFC-free R404a refrigerant. On/Off switch located behind access panel on operator's side.

ELECTRICAL CHARACTERISTICS... Operates on 120 volts, 60 cycle, single phase, 5 amps (running). Ten foot rubber power cord with grounded plug. NEMA 5-15P.

ACCESSORIES/OPTIONS...

- Stainless Steel Tray Shelf with Drop-down Brackets
- Stainless Steel Drop-Down End Shelf
- Vinyl or High Pressure Laminate Styling
- Elementary Height

SPECIFICATIONS

Specifications subject to change through product improvement & innovation.

CARTER-HOFFMANN
1551 McCormick Ave., Mundelein, IL 60060
Tel (847) 362-5500 • (800) 323-9793 • Fax (847) 367-8981
www.carter-hoffmann.com

Printed in U.S.A. 165 1207
Carter-Hoffmann is a registered trademark.

FEATURES & BENEFITS

FSFI35 & FAFI35 QUICK SERVE™ MOBILE MODULAR SERVING FREEZERS for pre-packaged food

Since 1947, Foodservice Equipment That Delivers!

STAINLESS STEEL CONSTRUCTION...

Stainless steel interior and exterior for easy sanitation and long lasting clean appearance.

SELF SERVICE DESIGN...

Speeds up service and saves labor because kids serve themselves. Large capacity well reduces number of restocking trips.



COLD WALL FREEZER COMPARTMENT...

All stainless steel compartment with coved corners, stainless steel drain and stopper for easy cleaning. Capable of cooling to 0°F (-18°C).

TOP BI-FOLD LID WITH LID LOCKING BAR...

Keep unit closed and efficiently heating during non-serving times. Easily removed for serving. Locking bar secures unit during unsupervised times.

EASY ROLLING ALL SWIVEL CASTERS...

5" diameter industrial grade casters with rubber tread for easy maneuvering and maximum load strength. All casters with brakes.

COMPLETELY MODULAR...

All carts can be used as individual serving units or integrated into straightline and scramble serving lines. Quick action finger operated positive latches easily connect serving units together.

MANY ACCESSORIES AVAILABLE... A variety of vinyls and high pressure laminates are available for styling to match decor. Additional accessories and base modules can be supplied to increase the flexibility and operator efficiency of one unit or a complete line-up.

1551 McCormick Avenue, Mundelein, Illinois 60060
Tel. (847)362-5500 • (800)323-9793 • Fax (847)367-8981
www.carter-hoffmann.com

