

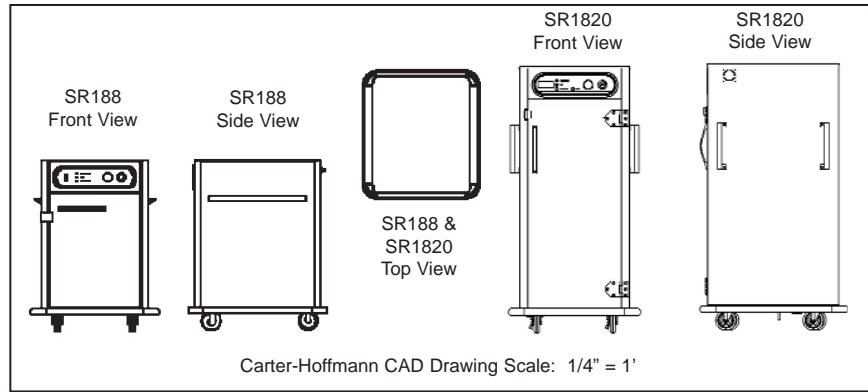

SR188 & SR1820 ENDURAHEAT™ SATELLITE TRANSPORT CARTS

Heat Retention Carts for Bulk Food



CARTER-HOFFMANN
11
FOOD SERVICE EQUIPMENT
HEATED TRANSPORT CARTS

SPECIFICATIONS

Model Number	Tray/Pan Capacity*		Slide Pairs	Inside Working Height		Overall Dimensions						Caster Diameter		Shipping Weight	
	18"x26"	12"x20"		in	mm	Height		Depth		Width		in	mm	lbs	kgs
						Standard	in	mm	in	mm	in				
<input type="checkbox"/> SR188	6	12	6	23 1/2	597	45 1/2	1156	35	889	31 3/4	806	6	152	285	130
<input type="checkbox"/> SR1820	12	24	12	45 3/4	1162	67 1/2	1715	35	889	31 3/4	806	6	152	440	200

* Capacity shown at 3 1/2" spacing. Tray slides adjustable on 1 3/4" increments.

CONSTRUCTION... Completely welded cabinet construction with outer cabinet formed and welded to base. All seams turned in to eliminate raw edges.

CABINET MATERIAL... All stainless steel; polished exterior.

BASE FRAME... 12 gauge stainless steel extended full depth bolsters.

CASTERS... 6" balloon casters. Plate mounted and bolted to base in offset wheel-ahead pattern. Delrin sleeve axle bearings and double ball bearing swivel. Zerk grease fittings. Two casters fitted with brakes.

BUMPER... Non-marking grey vinyl bumper set in heavy-duty 3/16" thick extruded aluminum frame with reinforced corner "cut-outs."

INSULATION... High density fiberglass, full 2" thick continuous wrap-around type in top and sides.

THERMOMETER... Dial type with remote sensing bulb.

DOOR... Recessed within cart walls, top and base. Welded double panel stainless steel pocket door. Polished exterior. Filled with 2" thick high density fiberglass insulation. Large curved door handle for easy grasp.

HINGES... 12 gauge stainless steel strap hinges with 3/8" diameter stainless steel pins, fully welded to cabinet and doors.

DOOR CLOSURE... Pocket-style door with magnetic closure. Gasketless design with side mount transport latch with padlock provision.

HANDLES... SR188: Two 1" stainless steel horizontal tubular handles mounted to sides of cabinet on top edge. SR1820: Four 1" stainless steel tubular handles. Two vertically mounted and bolted with backup plates to each side of the cabinet.

RACK ASSEMBLIES... Removable solid stainless steel universal slides placed into 18 gauge stainless steel baffles. Tray slides fully adjustable at 1 3/4" spacing. Standard spacing at 3 1/2" centers.

HEATING SYSTEM... 1500 watt blower heater. Patented solid to solid phase change heat retention material located in floor of cabinet. High impedance protected, internally cooled fan motor. Auto reset high-limit switch to protect all internal electrical components. Recessed control panel. Three-position toggle switch with off, convection & EnduraHeat settings. Power indicating light, EnduraHeat charge ready light, full range thermostat control knob.

ELECTRICAL CHARACTERISTICS... Operates on 120 volts, 60 cycle, single phase, 1500 watts, 12.5 amps. Ten foot 3 wire rubber cord with 3 prong grounding plug. NEMA 5-20P.

PERFORMANCE... Capable of heating to 200° F (94° C). Convection preheat to 160° F (71° C) in approximately 20 minutes. EnduraHeat mode charge/preheat time in approximately one hour.

ACCESSORIES/OPTIONS...

- Alternate caster sizes and types
- Four wheel brakes
- Menu card holder (5"x7" or 8.5"x11")
- Curved push handles (SR1820 only)
- 6" extended width tray slides
- Alternate electrical configuration

Specifications subject to change through product improvement & innovation.

US Patent Nos.
7,102,103 B2 &
7,394,042 B2

CARTER-HOFFMANN

1551 McCormick Ave., Mundelein, IL 60060
Tel (847) 362-5500 • (800) 323-9793 • Fax (847) 367-8981
www.carter-hoffmann.com



Printed in U.S.A. F33 0910
Carter-Hoffmann is a trademark
of Carter-Hoffmann, LLC

FEATURES & BENEFITS

1551 McCormick Avenue, Mundelein, Illinois 60060
 Tel. (847)362-5500 • (800)323-9793 • Fax (847)367-8981
www.carter-hoffmann.com



SR188 & SR1820 ENDURAHEAT™ TRANSPORT CARTS

Since 1947, Foodservice Equipment That Delivers!

HANDLES... Stainless steel tubular handles bolted to all four corners for easy maneuvering. Allow secure tie-down support for easy transport.

REMOVABLE STAINLESS STEEL TRAY SLIDE ASSEMBLIES... Baffles and slides can be removed without tools for easy cleaning and adjusting pan spacing.

STAINLESS STEEL CONSTRUCTION... All stainless steel construction. Designed to withstand the abuse of transport applications and is easy to clean.

EASY ROLLING BALLOON CASTERS IN OFFSET WHEEL AHEAD PATTERN... Only one wheel can pass over uneven surfaces at one time. Cabinet glides easily across grates, thresholds and truck lift gates.



SR1820

ENDURAHEAT HEAT RETENTION SYSTEM... Blower system for fast heat up, recovery and even heat distribution throughout cabinet. One hour EnduraHeat charge/preheat time. Flexible system can be operated in convection or EnduraHeat mode. Once charged, EnduraHeat system will maintain serve safe temperatures for two hours.

EnduraHeat module can be removed to make cart cleaning easy.

RECESSED DOOR... Flush mounted design protects door from damage & coming out of alignment during transport. Gasketless for low maintenance.

HEAVY-DUTY HINGES... Stainless steel strap hinges with 3/8" stainless steel pins, bolted and welded to door and cabinet, with back-up plates withstand abuse of transport.

FULL PERIMETER BUMPER... Heavy-duty wrap-around aluminum bumper with grey vinyl insert. Protects entire cart and facility walls from damage.



SR1820

