

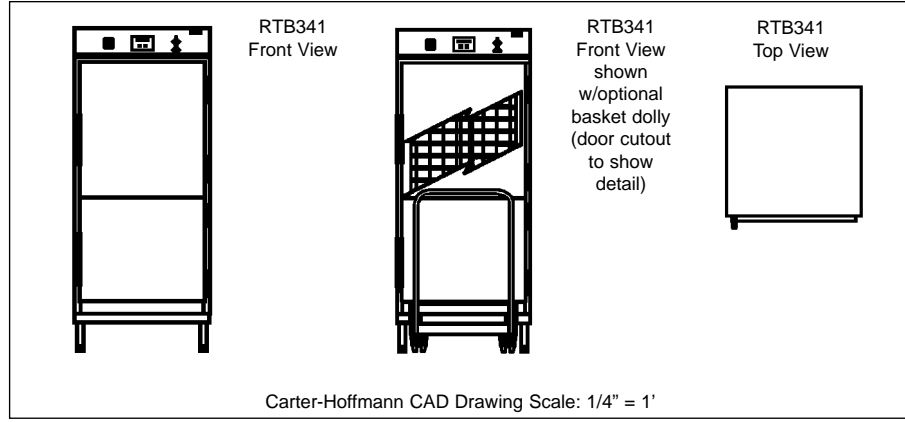

# RTB341

## QUICKTHERM SCHOOL RETHERMALIZER CABINET with roll-in basket dolly

CARTER-HOFFMANN **11** FOOD SERVICE EQUIPMENT  
RETHERMALIZERS



Model Number	Basket Capacity* 13 3/8 x 25 7/8	Basket Spacing		Inside Working Height		Overall Dimensions				Leg Height		Shipping Weight			
		in	mm	in	mm	Height	Depth	Width	in	mm	lbs	kgs			
RTB341	32	3	76	58	1473	78 1/2	1994	35 5/8	905	35 3/8	899	6	152	450	205

\*Roll-in basket dolly sold separately

**CONSTRUCTION...** Completely welded cabinet construction with outer cabinet formed to base and welded. All seams turned in to eliminate raw edges.

**CABINET MATERIAL...** All stainless steel; 20 gauge polished exterior and 20 gauge interior.

**BASE FRAME...** 14 gauge stainless steel perimeter supports with 12 gauge caster supports.

**INSULATION...** High density fiberglass, full 1" thick continuous wrap-around type in top, bottom and sides.

**DOORS...** Field reversible dutch doors. Double wall stainless steel construction. 20 gauge interior and exterior with fiberglass insulation.

**HINGES...** Adjustable self-closing edgemount hinges with chrome plate finish.

**LATCHES...** Heavy-duty edgemount latch with magnetic catch.

**ADJUSTABLE LEGS...** Adjust for uneven floor surfaces.

**CONTROLLER...** Solid state electronic controller with digital display. Programmable to store up to 12 four-step heat/hold cycles. Factory preset for four standard rethermalization modes and one hold mode. Field programmable.

**HEATING SYSTEM...** Top mounted heater. Inconel-sheathed heating elements. High impedance protected, internally cooled fan motors. Precision engineered and balanced interior heat duct system.

**ELECTRICAL CHARACTERISTICS...** Operates on 208 volt, 60 amp, 18 kw, 60 Hz, three phase. Ten foot rubber cord with 3 prong IEC type grounding plug.

**PERFORMANCE...** Capable of rethermalizing prepacked food items from 38°F. (3°C.) to 165°F. (74°C.) in one hour or less (actual times may vary).

Note: Most areas do not require ventilation. Check with local vent hood codes.

**BASKET DOLLY...** All welded aluminum construction w/ stainless steel removable push handle. Pushes into RTB341 with ease. Holds 32 Arlington School Baskets. Baskets slide out from any location in rack for easy access. Angle slides spaced on 3" centers. Dimensions: 31 5/8" deep x 32" wide x 65 1/2" high. All swivel 5" black polyurethane casters. **SOLD SEPARATELY.**

- OPTIONS & ACCESSORIES...**
- 9kw, 208 volt, 50 amps, single phase, NEMA 6-50P plug. Note: will extend retherm time to two hours.
  - Pre-programmed custom menu settings. Submit menu with order.
  - #47 Arlington baskets

# SPECIFICATIONS

Specifications subject to change through product improvement & innovation.



**CARTER-HOFFMANN**  
1551 McCormick Ave., Mundelein, IL 60060  
(847) 362-5500 • (800) 323-9793 • Fax (847) 367-8981  
[www.carter-hoffmann.com](http://www.carter-hoffmann.com)

Printed in U.S.A. H18 0808  
Carter-Hoffmann is a trademark of Carter-Hoffmann, LLC

# FEATURES & BENEFITS

1551 McCormick Avenue, Mundelein, Illinois 60060  
Tel. (847)362-5500 • (800)323-9793 • Fax (847)367-8981  
[www.carter-hoffmann.com](http://www.carter-hoffmann.com)



## EASY MEAL LOADING

**SYSTEM...** Simply secure the prepacked food trays onto the basket dolly, roll the dolly into the cabinet and close the door, press a button and go!

## PRECISION ENGINEERED

**HEAT DUCT SYSTEM...** Even and efficient heating throughout the entire cabinet assures uniform temperatures for safe and consistent heating of product.

## STAINLESS STEEL

**CONSTRUCTION...** All stainless steel interior and exterior for easy sanitation and long lasting clean appearance.

## VERSATILE REETHERMALIZATION

**CAPABILITY...** Rethermalizes a variety of pre-packed food items from chilled to serving temperature... most in an hour or less.

## RTB341

## QUICKTHERM SCHOOL RETHERMALIZER CABINET

with Roll-in Basket Dolly

*Since 1947, Foodservice Equipment That Delivers!*



RTB341

## EASY GRIP DOOR HANDLE WITH MAGNETIC CATCH...

Ergonomically designed for easy opening. Keeps door positively closed for optimal cabinet performance.

## OPERATOR FRIENDLY SOLID STATE CONTROLLER...

Easy to use controls. Menu driven programmable rethermalization cycles for up to twelve menu cycles. Four-stage retherm cycle allows user to control retherm time and temperatures with precision. 18kw power allows retherm from refrigerated to serving temperatures in an hour or less. Note: retherm times will vary, depending on density and load of product. Submittal of menu with order for pre-programming of menu settings is recommended.

## EASY MEAL LOADING

**SYSTEM...** Cantilever design makes this basket dolly easy to roll into the cart. Accommodates #47 Arlington Baskets on angle slides. Removable handle can be stowed back into the dolly and prevent the door from being opened during the retherm cycle.

**NOTE: BASKET DOLLY AND/OR ARLINGTON BASKETS SOLD SEPARATELY.**



ANSI/NSF 4