

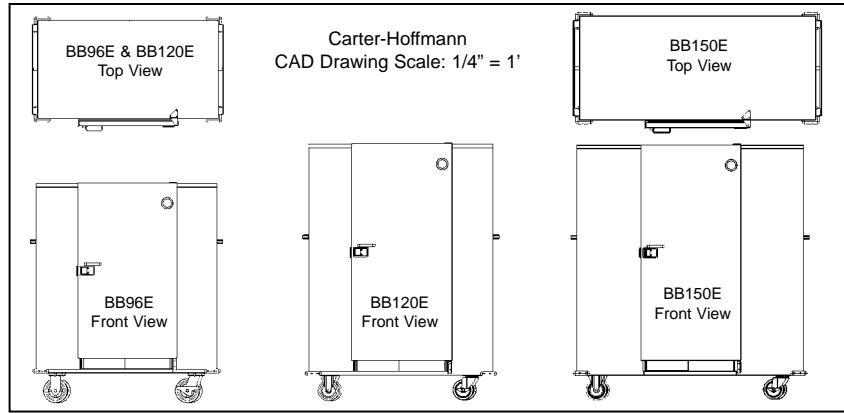

BB96E, BB120E & BB150E VALUE BANQUET CARTERS

for plates 8-3/4" to 10-1/2" in diameter

CARTER-HOFFMANN
11
BANQUET CARTS
FOOD SERVICE EQUIPMENT



Model Number	Plate Capacity*			Number of Shelves	Clearance Between Shelves		Shelf Size		Overall Dimensions			Caster Diameter		Shipping Weight				
	with "P" carriers	with "C" carriers	without carriers		in	mm	in	mm	Height in	mm	Depth in	mm	Width in	mm	in	mm	lbs	kgs
<input type="checkbox"/> BB96E	96	120	120	3	13	330	42 ¹ / ₂ x22	1080x559	53 ⁷ / ₈	1368	28 ¹ / ₂	724	48 ¹ / ₈	1222	5	127	358	162
<input type="checkbox"/> BB120E	120	144	144	3	16	406	42 ¹ / ₂ x22	1080x559	63 ³ / ₈	1610	28 ¹ / ₂	724	48 ¹ / ₈	1222	5	127	390	177
<input type="checkbox"/> BB150E	150	180	180	3	16	406	53 ¹ / ₄ x22	1353x559	63 ³ / ₈	1610	28 ¹ / ₂	724	58 ⁷ / ₈	1495	5	127	442	200

*Capacity based on common plate depth and combined plate/cover height of 2.5". Due to the variety of plate thicknesses and depths, as well as plate cover heights, actual capacity may vary.

CONSTRUCTION... Completely welded double wall cabinet construction with outer cabinet formed and welded to base. All seams turned in to eliminate raw edges.

CABINET MATERIAL... All stainless steel construction; 20 gauge polished exterior and 24 gauge interior.

BASE FRAME... 12 gauge stainless steel full depth bolsters with 1"x1" stainless steel perimeter channel supports.

CASTERS... 5" diameter, industrial grade polyurethane casters. Two swivel and two rigid. Sealed roller axle bearing and double ball bearing swivel. Zerk grease fittings. Plate mounted and bolted to base in offset "wheel ahead" pattern. Two casters fitted with brakes.

CORNER BUMPERS... Four snug fit non-marking gray vinyl corner bumpers are mounted at the base of the cabinet.

INSULATION... 1" thick high density continuous wrap-around type fiberglass insulation with 1 1/2" thickness on top.

GASKET... High temperature silicone gasket mounted to cabinet.

DOORS... Welded double stainless steel door. Filled with 1" thick fiberglass insulation.

HINGES... Concealed, stainless steel hinge with 5/16" pin.

PUSH HANDLES... Two horizontal full width heavy-duty aluminum push handles with back-up plates. Mounted to each end of the cabinet.

LATCH... Flush mounted, heavy-duty sliding latch with exclusive grip handle.

SHELVES... Welded, duplex nickel-plated removable wire shelves.

THERMOMETER... Dial type with remote sensing bulb and sensing bulb protector. Mounted to door.

HEATING SYSTEM... Bottom mounted heater. Stainless steel construction. Removable without tools. 1600 watt inconel-sheathed heating element. High impedance protected, internally cooled fan motor. Full range thermostat and power indicating light.

ELECTRICAL CHARACTERISTICS... Operates on 120 volts, 60 cycle, single phase, 1650 watts, 13.7 amps. Ten foot rubber cord with 3 prong grounding plug. NEMA 5-15P plug.

PERFORMANCE... Capable of heating to 200° F (94° C). Preheat to 160° F (71° C) in approximately 20 minutes.

ACCESSORIES/OPTIONS...

- 4 wheel brakes
- Alternate electrical configurations
- On/Off heater toggle switch
- Top mounted transport latch
- Locking paddle latch
- Lexan thermometer cover
- Cold plate
- Alternate caster sizes & types
- Menu card holder
- Plate carriers - specify open plate "P" type or covered plate "C" type

Specifications subject to change through product improvement & innovation.

SPECIFICATIONS

Printed in U.S.A. B57 1110
Carter-Hoffmann is a trademark of Carter-Hoffmann LLC



CARTER-HOFFMANN
1551 McCormick Ave., Mundelein, IL 60060
(847) 362-5500 • (800) 323-9793 • Fax (847) 367-8981
www.carter-hoffmann.com



FEATURES & BENEFITS

BB96E, BB120E & BB150E VALUE BANQUET CARTERS

Since 1947, Foodservice Equipment That Delivers!

DOUBLE WALL STAINLESS STEEL CABINET... Strongest, most durable materials for long life. High density 1" thick fiberglass in walls and door, 1 1/2" thick on top for maximum heat retention.

HEAVY-DUTY STAINLESS STEEL BASE FRAME... 12 gauge caster bolsters with perimeter frame for rugged use and added durability.

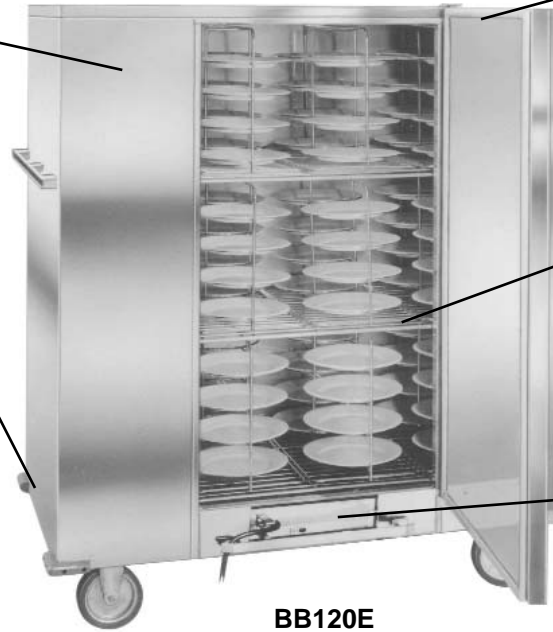

BB120E
(shown with optional
"P" plate carriers)

COMPLETELY WELDED TURNED-IN SEAM CONSTRUCTION... Adds rigidity to entire cabinet and eliminates raw edges for ease of cleaning and safety.

REMOVABLE WIRE SHELVES... Welded, duplex nickel-plated with reinforced shelf clips. Sturdy for heavy plate loads and removable for cleaning.

HIGH PERFORMANCE REMOVABLE HEATER... Blower system for fast heat up, recovery and even heat distribution throughout cabinet. Removable without tools for easy service and cabinet cleaning.



SNUG FIT CORNER BUMPERS... Protect corners of cart from damage and reduces cabinet depth vs carts with standard wrap-around bumper. Cart fits through narrower doorways.

5" DIAMETER INDUSTRIAL GRADE CASTERS WITH POLYURETHANE TREAD... Long lasting and easy rolling for maximum load and minimum maintenance. Two swivel and two rigid. Swivel casters fitted with brakes. Mounted to base in offset wheel-ahead pattern for easy rolling over uneven surfaces.

1551 McCormick Avenue, Mundelein, Illinois 60060
Tel. (847)362-5500 • (800)323-9793 • Fax (847)367-8981
www.carter-hoffmann.com



NSF/ANSI 4

ENERGY STAR