



BB64 & BB90 BANQUET CARTERS

for plates 8-3/4" to 10-1/2" in diameter

CARTER-HOFFMANN



FOOD SERVICE EQUIPMENT
HEATED SERVERS

SPECIFICATIONS

Printed in U.S.A. B35 1110
Carter-Hoffmann is a trademark
of Carter-Hoffmann, LLC

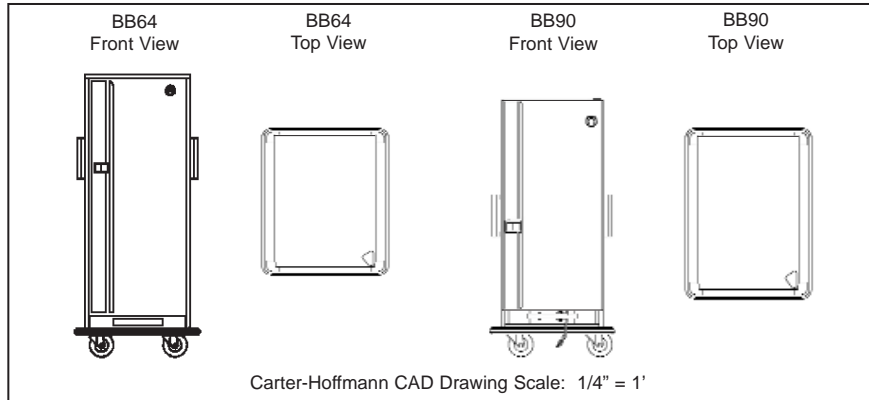

Model Number	Plate Capacity*			Number of Shelves	Clearance Between Shelves in (mm)	Shelf Size in (mm)	Overall Dimensions			Caster Diameter		Shipping Weight				
	with P carriers (qty)	with C carriers (qty)	w/o carriers (qty)				Height in mm	Depth in mm	Width in mm	in	mm	lbs	kg			
<input type="checkbox"/> BB64	64	80	84	4	13 ¹ (330)	22 ³ / ₄ x 26 ¹ / ₂ (578 x 673)	70 ³ / ₄	1797	36	914	30	781	6	152	336	153
<input type="checkbox"/> BB90	n/a	n/a	90	5	10 (254)	30 x 22 ¹ / ₂ (762 x 572)	63 ¹ / ₈	1603	42	1069	31	787	6	152	350	159

* Capacity based on common plate depth and combined plate/cover height of 2.5". Due to the variety of plate thicknesses and depths, as well as plate cover heights, actual capacity may vary.

¹ Top shelf clearance for BB64 is 16¹/₂" (419 mm)

CONSTRUCTION... Completely welded cabinet construction with outer cabinet formed and welded to base. All seams turned in to eliminate raw edges.

CABINET MATERIAL... All stainless steel construction; 20 gauge polished exterior and 24 gauge interior.

BASE FRAME... 12 gauge stainless steel full depth caster bolsters with 14 gauge stainless steel channels welded to bolsters.

CASTERS... 6" diameter, industrial grade caster with polyurethane tread. Sealed roller axle bearing and double ball bearing swivel. Plate mounted and bolted to base in offset "wheel ahead" pattern. Two casters fitted with brakes.

BUMPER... Non-marking gray vinyl bumper set in heavy-duty 3/16" thick extruded aluminum frame with reinforced corner cutouts.

INSULATION... 1" thick high density continuous wrap-around type fiberglass insulation with 1-1/2" thickness on top.

DOOR... Welded double panel stainless steel door. Filled with 1" thick fiberglass insulation. Decorative red vinyl door stripe.

HINGES... Concealed stainless steel hinges with 5/16" pin.

GASKET... High temperature silicone gasket withstands high temperatures.

PUSH HANDLES... Two 1" diameter stainless steel tubular handles bolted to cabinet.

LATCH... Flush mounted heavy-duty sliding latch with exclusive grip handle.

SHELVES... Welded, duplex nickel-plated removable wire shelves.

THERMOMETER... Dial type with remote sensing bulb and sensing bulb protector. Mounted to door.

HEATING SYSTEM... Bottom mounted heater. Stainless steel construction. Removable without tools. 1600 watt inconel-sheathed heating element. High impedance protected, internally cooled fan motor. Full range thermostat and power indicating light.

ELECTRICAL CHARACTERISTICS... Operates on 120 volts, 60 cycle, single phase, 1650 watts, 13.7 amps. Ten foot rubber cord with 3 prong grounding plug. NEMA 5-15P.

PERFORMANCE... Capable of heating to 200° F (94° C). Preheat to 160° F (71° C) in approximately 25 minutes.

ACCESSORIES/OPTIONS...

- Canned heat adapters
- Top mounted transport latch
- Locking paddle latch
- Menu card holder
- Lexan thermometer cover
- 4 wheel brakes
- Alternate caster sizes and types
- Alternate electrical configurations
- Passive humidity pan
- Plate carriers: "P" or "C" type (BB64 only)
- Cold plate

Specifications subject to change through product improvement & innovation.



CARTER-HOFFMANN
1551 McCormick Ave., Mundelein, IL 60060
(847) 362-5500 • (800) 323-9793 • Fax (847) 367-8981
www.carter-hoffmann.com



FEATURES & BENEFITS

1551 McCormick Avenue, Mundelein, Illinois 60060
 Tel. (847)362-5500 • (800)323-9793 • Fax (847)367-8981
www.carter-hoffmann.com



BB64 & BB90 CLASSIC CARTER™ BANQUET CARTERS

Since 1947, Foodservice Equipment That Delivers!

COMPLETELY WELDED TURNED-IN SEAM CONSTRUCTION... Adds rigidity and strength to entire cabinet for long life and eliminates raw edges for ease of cleaning and safety.

DOUBLE WALL STAINLESS STEEL CABINET... Strongest, most durable materials for long life. High density fiberglass for maximum heat retention.

HEAVY-DUTY STAINLESS STEEL BASE FRAME... 12 gauge caster bolsters with perimeter frame for rugged use and added durability.



BB90

SPACE-SAVING DESIGN... Upright design of cabinets uses vertical space for smaller footprint. BB64: Stack plates two deep. BB90: Stack plates three deep.

HIGH PERFORMANCE HEATER... Blower system for fast heat up, recovery and even heat distribution throughout cabinet. Unit is removable without tools for easy cleaning.

POLYURETHANE TREAD CASTERS WITH SEALED ROLLER BEARING... Long lasting and easy rolling for maximum load and minimum maintenance.

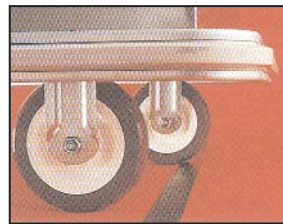

OFFSET "WHEEL AHEAD" PATTERN... Only one wheel can pass over uneven surfaces at a time for easy handling and steering.



FLUSH-MOUNTED SLIDING DOOR LATCH WITH GRIP HANDLE... Designed for transport applications. Door remains closed during transport. Flush design protects cart from damage.



CONCEALED STAINLESS STEEL HINGE WITH 5/16" PIN... Keeps doors properly aligned and withstands rugged use.



HEAVY-DUTY NON-MARKING BUMPER... Set in 3/16" thick extruded aluminum frame with reinforced corner cut-outs. Protects doorways, walls and cart from damage.

