



BB100 CONVERTIBLE BANQUET CARTER for Pre-plated Banquet Meals, Trays and Pans

CARTER-HOFFMANN
HEATED SERVERS



FOOD SERVICE EQUIPMENT

SPECIFICATIONS

Printed in U.S.A. B45 0911
Carter-Hoffmann is a trademark
of Carter-Hoffmann, LLC



BB100

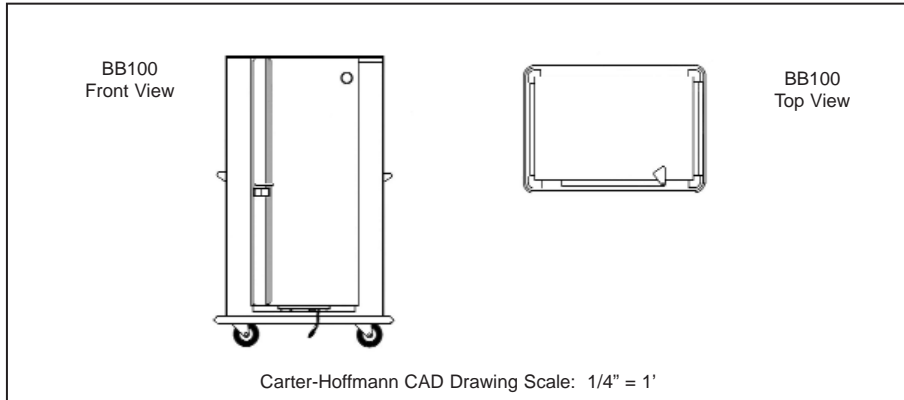

BB100
Front View

BB100
Top View

Carter-Hoffmann CAD Drawing Scale: 1/4" = 1'

Model Number	Capacity			Number of Shelves	Clearance Between Shelves in (mm)	Shelf Size in (mm)	Overall Dimensions			Caster Diameter		Shipping Weight				
	Plates in "P" carriers	Covered Plates	**Tray Slides (optional)				Height in mm	Depth in mm	Width in mm	in	mm	lbs	kg			
														in	mm	
BB100	96 Plates in 12 (8P) carriers	96 to 120* with/without 12 (8C) carriers	15 pair at 3.5" (87mm) spacing	4	13 (330)	23 x 22 ⁹ / ₁₆ (840 x 673)	69 ¹ / ₂	1765	34	863	64 ¹ / ₄	1632	6	152	378	172

* Requires shallow dome and plate. See "Clearance Between Shelves."
** Optional tray slides may be used in lieu of shelves (see accessories/options)

CONSTRUCTION... Completely welded cabinet construction with outer cabinet formed and welded to base. All seams turned in to eliminate raw edges.

CABINET MATERIAL... All stainless steel construction; 20 gauge polished exterior and 24 gauge interior.

BASE FRAME... 12 gauge stainless steel full depth caster bolsters with 14 gauge 1" x 1" stainless steel perimeter channel supports welded to bolsters.

CASTERS... 6" diameter, industrial grade caster with polyurethane tread. Sealed roller axle bearing and double ball bearing swivel. Plate mounted and bolted to base in offset "wheel ahead" pattern. Two casters fitted with brakes.

BUMPER... Non-marking gray vinyl bumper set in heavy-duty 3/16" thick extruded aluminum frame with reinforced corner cutouts.

INSULATION... 1" thick high density continuous wrap-around type fiberglass insulation in walls, door and top.

GASKET... High temperature silicone gasket mounted to cabinet.

DOOR... Welded double panel stainless steel door. Filled with 1" thick fiberglass insulation. Decorative red vinyl door stripe.

HINGES... Concealed stainless steel hinges with 5/16" pin.

PUSH HANDLES... Two horizontal 1" diameter stainless steel tubular handles bolted to cabinet.

LATCH... Flush mounted heavy-duty sliding latch with exclusive grip handle.

SHELVES... Welded, duplex nickel-plated removable wire shelves.

OPTIONAL PAN/TRAY RACK ASSEMBLIES... Optional stainless steel tray slide assemblies are interchangeable with wire shelves. Tray capacities are: 15 18"x26" (G/N 2/1) pans or 30 12"x20" (G/N 1/1) pans.

THERMOMETER... Dial type with remote sensing bulb and sensing bulb protector. Mounted to mullion.

HEATING SYSTEM... Bottom mounted heater. Stainless steel construction. Removable without tools. 1600 watt inconel-sheathed heating element. High impedance protected, internally cooled fan motor with long life bearings. Full range thermostat & power indicating light.

ELECTRICAL CHARACTERISTICS... Operates on 120 volts, 60 cycle, single phase, 1650 watts, 13.7 amps. Ten foot rubber cord with 3 prong grounding plug. NEMA 5-15P.

PERFORMANCE... Capable of heating to 200° F (94° C). Preheat to 160° F (71° C) in approximately 25 minutes.

- ACCESSORIES/OPTIONS...**
- Optional stainless steel tray racks
 - Top mounted transport latch
 - Locking paddle latch
 - Menu card holder
 - Lexan thermometer cover
 - 4 wheel brakes
 - Alternate caster sizes and types
 - Alternate electrical configurations
 - Passive humidity pan
 - Cold plate
 - Plate carriers: specify covered "C" type or open "P" type

Specifications subject to change through product improvement & innovation.



CARTER-HOFFMANN
1551 McCormick Ave., Mundelein, IL 60060
(847) 362-5500 • (800) 323-9793 • Fax (847) 367-8981
www.carter-hoffmann.com



FEATURES & BENEFITS

1551 McCormick Avenue, Mundelein, Illinois 60060
 Tel. (847)362-5500 • (800)323-9793 • Fax (847)367-8981
www.carter-hoffmann.com



BB100 CONVERTIBLE BANQUET CARTER

Since 1947, Foodservice Equipment That Delivers!



BB100

COMPLETELY WELDED TURNED-IN SEAM CONSTRUCTION... Adds rigidity and strength to entire cabinet for long life and eliminates raw edges for ease of cleaning and safety.

DOUBLE WALL STAINLESS STEEL CABINET... Strongest, most durable materials for long life. High density fiberglass insulation for maximum heat retention.

HEAVY-DUTY STAINLESS STEEL BASE FRAME... 12 gauge caster bolsters with 1"x1" stainless steel perimeter frame for rugged use and added durability.

HEAVY-DUTY NON-MARKING BUMPER... Set in 3/16" thick extruded aluminum frame with reinforced corner cut-outs. Protects doorways, walls and cart from damage.

POLYURETHANE TREAD CASTERS WITH SEALED ROLLER BEARING... Long lasting and easy rolling for maximum load and minimum maintenance.

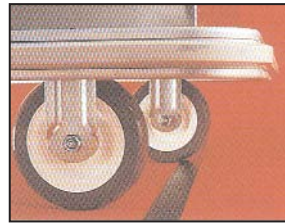

OFFSET "WHEEL AHEAD" PATTERN... Only one wheel can pass over uneven surfaces at a time for easy handling and steering.



FLUSH-MOUNTED SLIDING DOOR LATCH WITH GRIP HANDLE... Designed for transport applications. Door remains closed during transport. Flush design protects cart from damage.



CONCEALED STAINLESS STEEL HINGE WITH 5/16" PIN... Keeps doors properly aligned and withstands rugged use.



HIGH PERFORMANCE HEATER... Blower system for fast heat up, recovery and even heat distribution throughout cabinet. Unit is removable without tools for easy cleaning.

