

HEAT RETENTION TRANSPORT CART

MODELS: SR188 & SR1820

OWNER / OPERATOR'S MANUAL



CARTER-HOFFMANN

MANUFACTURED BY:

CARTER-HOFFMANN
1551 McCormick Avenue
Mundelein, IL 60060

Phone: 847-362-5500
Fax: 847-367-8981
Toll Free: 800-323-9793
Email: Service@Carter-Hoffmann.com



SR1820

EnduraHeat™

PATENTED HEAT RETENTION TECHNOLOGY
US Patent Numbers
7,102,103B2 & 7,394,042



TABLE OF CONTENTS

INTRODUCTION.....	2
SAFETY PRECAUTIONS & GENERAL INFORMATION.....	3
FEATURES & SPECIFICATIONS.....	4
UNPACKING, INSPECTION & FREIGHT DAMAGE.....	5
INSTALLATION & STARTUP	6
OPERATION & CONTROLS	7
CLEANING & CABINET MAINTENANCE.....	8
WIRING DIAGRAM	9
REPLACEMENT PARTS LIST.....	10
TROUBLESHOOTING GUIDE	11
SERVICE EXPECTATIONS.....	12
OWNER INFORMATION.....	13
WARRANTY STATEMENT.....	14



INTRODUCTION

Thank you for purchasing this Carter-Hoffmann appliance. Proper installation, professional operation and consistent maintenance of this appliance will ensure that it gives you the very best performance together with a reliable, long lasting and economical life. This manual contains information needed to properly install, operate and maintain this appliance

This product is the result of extensive research and field testing. The materials used were selected to provide optimum performance, maximum durability and an attractive appearance. At Carter-Hoffmann, every single unit is thoroughly inspected and functionally tested prior to shipment.

This Carter-Hoffmann cabinet provides the best environment for food products in bulk pans by regulating consistent the air temperature. This model uses hot circulating air (no moisture) and heat retention technology. EnduraHeat® heat retention technology enables heated transport of bulk food to remote locations, while maintaining serve safe holding temperatures for two hours, unplugged and without the use of canned fuel.

Due to the retention capabilities of the heating module, this unit eliminates the need for any type of canned fuel or "Sterno™" type heat. This is the major benefit of this unit, which will pay for itself over a short period of time.



The major benefits of EnduraHeat® technology are:

Safety: elimination of potential fire hazards from fuel use reduces the likelihood of employee burns

Cost: eliminate expense of canned fuel; no more scorched carpeting or other decor

Productivity: eliminate the extra labor involved to put cans into carts as well as monitor canned heat use

Sanitation: no open flames to scorch pans, burn food or scorch the cabinet interior; eliminate messy residue from canned fuel

Food Quality: no transfer of fuel fumes to ruin the flavor of food; food is maintained serving temperature

Extended Unplugged Hold Time: Cabinet temperature remains above 140°F for 2 hours, unplugged.



CAUTION: SAFE FOOD HOLDING PRACTICES RECOMMENDED

Cooking food to a safe temperature, holding at a temperature of at least 140° F is critical in the prevention of foodborne illness. Hold only cooked, hot food at 140°F or higher. This cabinet is not intended to cook or reheat food. Food must be at appropriate temperature before being placed into cabinet.

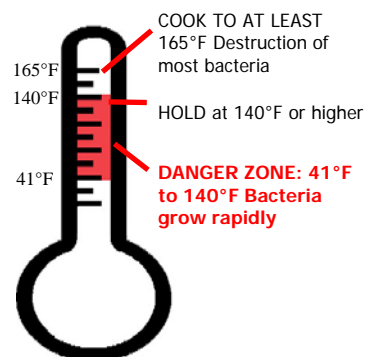

SAFETY PRECAUTIONS & GENERAL INFORMATION



CAUTION: Electric Shock Hazard

All servicing requiring access to non-insulated components must be performed by qualified service personnel. Do not open any access panels which require the use of tools. Failure to heed this warning can result in electrical shock. Disconnect this appliance from electrical power before performing any maintenance or servicing.



WARNING: Injury Hazard

All installation procedures must be performed by qualified personnel with full knowledge of all applicable electrical codes. Failure could result in property damage and personal injury.



WARNING Electric Shock Hazard

Appliance must be plugged into a properly grounded receptacle to prevent possible shock hazard. Electrical shock will cause death or serious injury.



CAUTION: Burn Hazard

Interior surfaces of the appliance may be HOT to the touch, and can cause serious burns.

GENERAL INFORMATION

- This appliance is intended for use in commercial establishments, where all operators are familiar with the appliance use, limitations and associated hazards.
- Operating instructions and warnings must be read and understood by all operators and users.
- This appliance is intended for use to holding pre-plated, covered, pre-cooked foods for human consumption. No other use is recommended or authorized by the manufacturer or its agents.
- Cleanliness of this appliance is essential to good sanitation. Read and follow all included cleaning instructions and schedules to ensure the safety of the food product.
- All included trouble shooting guides, component views and parts lists are included for general reference, and are intended for use by qualified service personnel.
- Knowledge of proper installation, operation and maintenance procedures is essential to ensure the safe operation of this oven.



CAUTION: Equipment Electrical Damage

DO NOT plug in or use this appliance until all *Installation Instructions* are read and followed. Damage to the appliance may occur if these instructions are not followed.

This manual is considered to be a permanent part of this appliance.

This manual must remain with the appliance if it is sold or moved to another location.

SERVICE / SAFETY

- Always have dry hands prior to using this piece of equipment.
- Turn OFF the unit (not all units have power switches) anytime the cabinet is not in use.
- If an electrical shock is felt when touching the cabinet, disconnect the power immediately and call Carter-Hoffmann Technical Service for assistance or service.
- If the power cord is frayed or the plug damaged, DO NOT plug into the electrical power receptacle. If it is already plugged in, turn off the main circuit breaker, usually located in the building's breaker box, then disconnect the plug.
- Disconnect the power cord before attempting any repairs to the cabinet or heating unit.
- Repairs to this unit must be by qualified personnel.
- DO NOT SPRAY WITH WATER OR CLEANING SOLUTIONS, or submerge the heating unit. Components and wiring present a high shock hazard when wet.
- Disconnect heating unit when cleaning cabinet or heating unit.
- Both the interior and exterior surfaces of this appliance can be hot to the touch and may cause burns.

PRODUCT SPECIFICATIONS AND OPERATING FEATURES



SR1820

MODEL NUMBER	PAN CAPACITY*		OVERALL DIMENSIONS						CASTER DIAMETER		SHIPPING WEIGHT	
			HEIGHT		DEPTH		WIDTH		in	mm	lbs	kgs
	12"x20"x2.5"	18"x26"	in	mm	in	mm	in	mm				
SR188	12	6	45 1/2	597	35	889	31 3/4	806	6	152	285	130
SR1820	24	12	67 1/2	1715	35	889	31 3/4	806	6	152	440	200

*Standard tray slide spacing at 3.5". Tray slides are adjustable at 1.5" spacing to accommodate varying pan depths.

CONSTRUCTION... Completely welded double wall cabinet construction with outer cabinet formed and welded to base. All seams turned in to eliminate raw edges.

CABINET MATERIAL... All stainless steel; polished exterior.

BASE FRAME... 12 gauge stainless steel full depth caster bolsters.

CASTERS... 6" diameter, industrial grade balloon casters. Plate mounted and bolted to base in offset, wheel-ahead pattern. Delrin sleeve axle bearings and double ball bearing swivel. Zerk grease fittings. Two casters fitted with brakes.

BUMPER... Non-marking gray vinyl bumper set in heavy-duty 3/16" thick extruded aluminum frame with reinforced corner cutouts.

INSULATION... 2" thick, high density continuous wrap-around type fiberglass insulation.

THERMOMETER... Dial type with remote sensing bulb and sensing bulb protector.

DOOR... Recessed within cart walls, top and base. Welded double panel stainless steel pocket door. Filled with 2" thick high density fiberglass insulation. Large curved door handle for easy grasp.

HINGES... 12 gauge stainless steel strap hinges with 3/8" diameter stainless steel pins, fully welded to cabinet and doors.

DOOR CLOSURE... Pocket style door with magnetic closure. Gasketless design with side-mounted transport latch with padlock provision.

HANDLE... SR188: Two horizontal full width stainless steel tubular handles, mounted to sides of cabinet on top edge. SR1820: Four 1" stainless steel tubular handles. Two vertically mounted and bolted with backup plates to each side of cabinet.

RACK ASSEMBLIES... Removable solid stainless steel universal slides placed into removable stainless steel baffles. Tray slides fully adjustable at 1-3/4" spacing. Standard spacing at 3-1/2" centers.

HEATING SYSTEM... 1500 watt blower heater located in top of cabinet. Patented solid-to-solid phase change heat retention material heated by 950 watt tubular element, located in bottom of cabinet. High impedance protected, internally cooled fan motor. Auto reset high-limit switch to protect all internal electrical components. Recessed control panel. Two position toggle switch with convection and EnduraHeat settings. Power indicating light, EnduraHeat charge ready light, full range thermostat control knob.

ELECTRICAL CHARACTERISTICS... Operates on 120 volts, 60 cycle, single phase, 1500 watts, 12.8 amps. Ten foot power cord with 3 prong grounding plug. NEMA 5-20P.

PERFORMANCE... Capable of heating to 200° F (94C°). Convection preheat to 160° F (71°C) in approximately 30 minutes. EnduraHeat mode charge time and preheat in approximately one hour. Preheat in standard convection mode is 20 minutes.

ACCESSORIES/OPTIONS...
 -Alternate caster sizes and types
 -Four wheel brakes
 -Menu card holder (5"x7" or 8.5"x11")
 -Curved push handles (SR8120 only)
 -6" extended width tray slides
 -Alternate electrical configuration

NOTE: Specifications subject to change through product improvement & innovation.



US Patent Nos. 7,102,103 B2 & 7,394,042 B2



UNPACKING, INSPECTION & FREIGHT DAMAGE



This appliance should be thoroughly cleaned prior to use.

See the CLEANING INSTRUCTIONS ON PAGE 8 in this manual.

NOTE: DO NOT discard the carton or other packing materials until you have inspected the appliance for hidden damage and checked it for proper operation.

Refer to *FREIGHT DAMAGE CLAIM PROCEDURE* below.

1. Remove the cabinet from shipping carton, ensuring that all packing materials and protective plastic has been removed from the unit.
2. Inspect all components for completeness and condition.
3. If any freight damage is present, a freight claim must be filed immediately with the shipping company.
4. **Freight damage is not covered under warranty.**
5. Check to insure all components are included: cabinet, instruction packet and additional accessories.
6. Read operation instructions completely.
7. Appliance should be thoroughly cleaned before use. See CLEANING INSTRUCTIONS ON PAGE 8 in this manual.

FREIGHT DAMAGE PROCEDURE

NOTE: For your protection, please note that equipment in this shipment was carefully inspected and packaged by skilled personnel before leaving the factory. Upon acceptance of this shipment, the transportation company assumes full responsibility for its safe delivery.

IF SHIPMENT ARRIVES DAMAGED:

1. **VISIBLE LOSS OR DAMAGE:** Be certain that any visible loss or damage is noted on the freight bill or express receipt, and that the note of loss or damage is signed by the delivery person.
2. **FILE CLAIM FOR DAMAGE IMMEDIATELY:** Regardless of the extent of damage. **Contact your dealer immediately.**
3. **CONCEALED DAMAGE:** If damage is unnoticed until the merchandise is unpacked, notify the transportation company or carrier immediately, and then file a "CONCEALED DAMAGE" claim with them. This should be done within fifteen (15) days from the date the delivery was made to you. **Be sure to retain the container for inspection.**

Carter-Hoffmann cannot assume liability for damage or loss incurred in transit, **freight damage is not covered under warranty.** We will, however, at your request, supply you with the necessary documents to support your claim.

INSTALLATION & STARTUP

NOTE: DO NOT discard the carton or other packing materials until you have inspected the appliance for hidden damage and tested it for proper operation.

Refer to *FREIGHT DAMAGE CLAIM PROCEDURE* on PAGE 5 of this manual.



WARNING: Risk of personal injury

Installation procedures must be performed by a qualified technician with full knowledge of all applicable electrical codes. Failure can result in personal injury and property damage.



CAUTION: Electrical Shock Hazard

The ground prong of the power cord is part of a system designed to protect you from electric shock in the event of internal damage. **DO NOT** cut off the large round ground prong or twist a blade to fit an existing receptacle.



IMPORTANT: Power cord is 10' long.

If necessary, contact a licensed electrician to install an appropriate 20 amp electrical circuit with NEMA 5-20R receptacle. **DO NOT** use an extension cord.



IMPORTANT:

Damage to unit due to being connected to the wrong voltage or phase is **NOT** covered by warranty.

Unpack the cabinet. Ensure that all packing materials and protective plastic has been removed from the unit. Inspect all components for completeness and condition.

For safe operation and maximum performance, locate the unit at least 2" from any wall or combustible material.

Install tray slides at 3.5" spacing (every other notch). Tabs on each end of the slides will fit into notches on side wall baffles. Simply angle the slide so that the top of each tab slides into the notch; then turn the slide to level position.

GROUNDING INSTRUCTIONS

This appliance is equipped with a cord having a grounding wire with a grounding plug which must be plugged into an outlet that is properly installed and grounded. In the event of an electrical short circuit, grounding reduces the risk of electric shock by providing an escape wire for the electric current.

WARNING—Improper use of the grounding can result in a risk of electric shock. Consult a qualified electrician or service agent if the grounding instructions are not completely understood, or if doubt exists as to whether the appliance is properly grounded.

START UP

Appliance should be thoroughly cleaned before use. See *CLEANING INSTRUCTIONS*, page 8.

1. Familiarize yourself with the controls. Plug the power cord of the cabinet into a properly grounded NEMA 5-20R electrical receptacle according to the electrical information provided below. **DO NOT MODIFY CORD PLUG.**

Volts : 120
Watts: 1500
Amps: 12.5

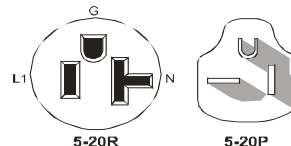

2. Set POWER switch to the "ON" position.
3. Do not load product into the cabinet. Allow the heat to remove any residual oils which may adhere to inside metal surfaces. A slight emission of smoke is common during the first few hours of operation.

OPERATION & CONTROLS

Before using, familiarize yourself with the heater controls. Read entire manual before using unit.



ATTENTION:

Whenever possible, heating unit should remain running to ensure maximum product temperatures, especially after finishing the food loading stage.



DO NOT USE ANY CANNED FUEL IN THIS CABINET!



This cabinet is designed to eliminate the need for canned fuel.

USE OF CANNED FUEL IN ENDURAHEAT CABINETS WILL VOID THE WARRANTY!



CAUTION: SAFE FOOD HOLDING PRACTICES RECOMMENDED

Cooking food to a safe temperature, holding at a temperature of at least 140°F is critical in the prevention of foodborne illness. Hold only cooked, hot food at 140°F or higher. This cabinet is not intended to cook or re-heat food. Food must be at appropriate temperature before being placed into cabinet.

EnduraHeat® Mode:

1. One hour before loading food, turn the temperature dial to 200° F. Flip the toggle switch on heating unit down to “EnduraHeat”. The white indicator lamp will illuminate.
2. Allow one hour for EnduraHeat® charging and cabinet pre-heat to approximately 180°F. Do not open cabinet doors during preheat phase. The green “Ready” light will illuminate when system is fully charged.
3. Load pans as quickly as possible and close doors. The cabinet temperature will drop. Keep heating unit plugged in during loading to keep food warm.
4. Once pans are loaded, unplug heating unit, wrap cord around cord wrap bracket .
5. Transport food to serving area. Do not open cabinet doors until ready to serve. Food will remain at serving temperatures for approximately two hours.
6. If holding time is extended beyond two hours and cabinet temperature drops below 145° F, move cart to location where 20 Amp electricity is available and plug in heater. Flip toggle switch to “Convection” mode and operate heater until food are served.
7. When removing items, start at the bottom of the cabinet and work to the top shelf position. This will keep food warmer and reduce spillage onto items on lower shelves.



Convection Heat Mode:

1. At least 30 minutes before loading pans, turn the temperature dial to 200°F. Flip toggle switch on heating unit up to “Convection” mode. White indicator lamp will illuminate.
2. Allow at least 20 minutes for cabinet to preheat to approximately 180°F.
3. Load pans and close doors. During loading, the cabinet temperature will drop. Keep unit plugged in to electrical source to keep meals warm. Try not to move the cart right away; wait 10-15 minutes until the cabinet recovers air temperature.
4. To transport to serving location, unplug heater, wrap cord around cord wrap bracket and transport food to serving area.
5. Upon reaching the serving area, unwind the power cord and reconnect the heater to a 20 Amp outlet as quickly as possible.
6. When removing items, start at the bottom of the cabinet and work to the top shelf position. This will keep food warmer and reduce spillage onto items on lower shelves.



ATTENTION:

Whenever possible, heating unit should remain running to ensure maximum product temperatures, especially after finishing the food loading stage.

CLEANING & CABINET MAINTENANCE



WARNING: ELECTRIC SHOCK HAZARD

Unplug the unit from electric power before performing cleaning or maintenance.



WARNING: BURN HAZARD

Allow the unit to cool before performing any cleaning or maintenance procedures.



WARNING: ELECTRIC SHOCK HAZARD

DO NOT spray or splash water on the heater, control panel, timer or wiring.



CAUTION: Heating unit weighs approximately 50 lbs.

Two people are required to remove the heater assembly from the cabinet.

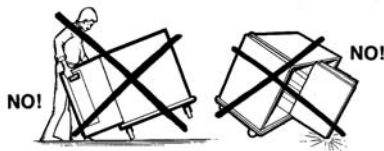

Turn the main power switch OFF, unplug and allow the unit to cool completely before cleaning. DO NOT spray or splash water on the heater, control panel, timer or wiring.

1. Tray slides are easily removed without tools for cleaning, Simply lift up and pull out. The tray slides may be hand washed or run through an automatic washer.
2. Before cleaning, unplug the heating assembly. Remove the heater by grasping handles on each side of the heater. Pull up and lift out. Disconnect power cord from heater assembly before removing completely.
3. To clean stainless steel surfaces use only cleansers, detergents, degreasers, or sanitizers that are certified to be "chloride-free" and "phosphate-free," and cleansers, degreasers, or sanitizers only in the recommended concentrations. **DO NOT** exceed recommended concentrations or mixing ratios. After cleaning and sanitizing, rinse all exposed surfaces thoroughly with large amounts of clean, clear water. Wipe off any standing liquid or residue from all surfaces, corners and rear edges.
4. Vinyl trim should be washed with a chlorine-free detergent and water. Rinse thoroughly with clear water and allow to dry. Never use abrasive cleaners, waxes, car polish, or substances containing strong aromatic solvents or alcohol. Use of direct **steam / hot water** cleaning at temperatures above 190°F may result in "bubbling" or loosening of vinyl adhesive.

IMPORTANT: Cleansers, detergents, degreasers, sanitizers or bleaching agents that contain **chlorides or phosphates will cause permanent damage** to stainless steel products. This damage appears as pits, eruptions, voids, small holes, cracks, severe discolorations or dulling of the metal finish. Water with a high chlorine content can also damage stainless steel. If unsure of your water quality, we recommend you have it tested. **THIS DAMAGE IS PERMANENT, COSTLY TO REPAIR, AND IS NOT COVERED BY WARRANTY.**

RECOMMENDED TIPS FOR CLEANING STAINLESS STEEL

PURPOSE	FREQUENCY	CLEANING AGENT	METHOD OF APPLICATION
Routine cleaning	Daily	Soap or ammonia or detergent and water	Swab with cloth. Rinse with clear water, wipe dry.
Smears and fingerprints	As needed	Stainless steel cleaner or similar products	Rub with cloth as directed on package. Rub in direction of grain of stainless steel. Do not use on vinyl trim or control panel.
Stubborn spots and stains	Daily or as needed	Any chloride-free or phosphate-free cleanser	Apply with damp sponge or cloth. Rub in direction of grain. Rinse thoroughly. Do not use on vinyl trim or control panel.
Hard water spots	Daily or as needed	Vinegar	Swab with cloth. Rinse with clear water, wipe dry.

WIRING DIAGRAM

120 VOLT, 1500 WATT, 12.5 AMP, 1 PH

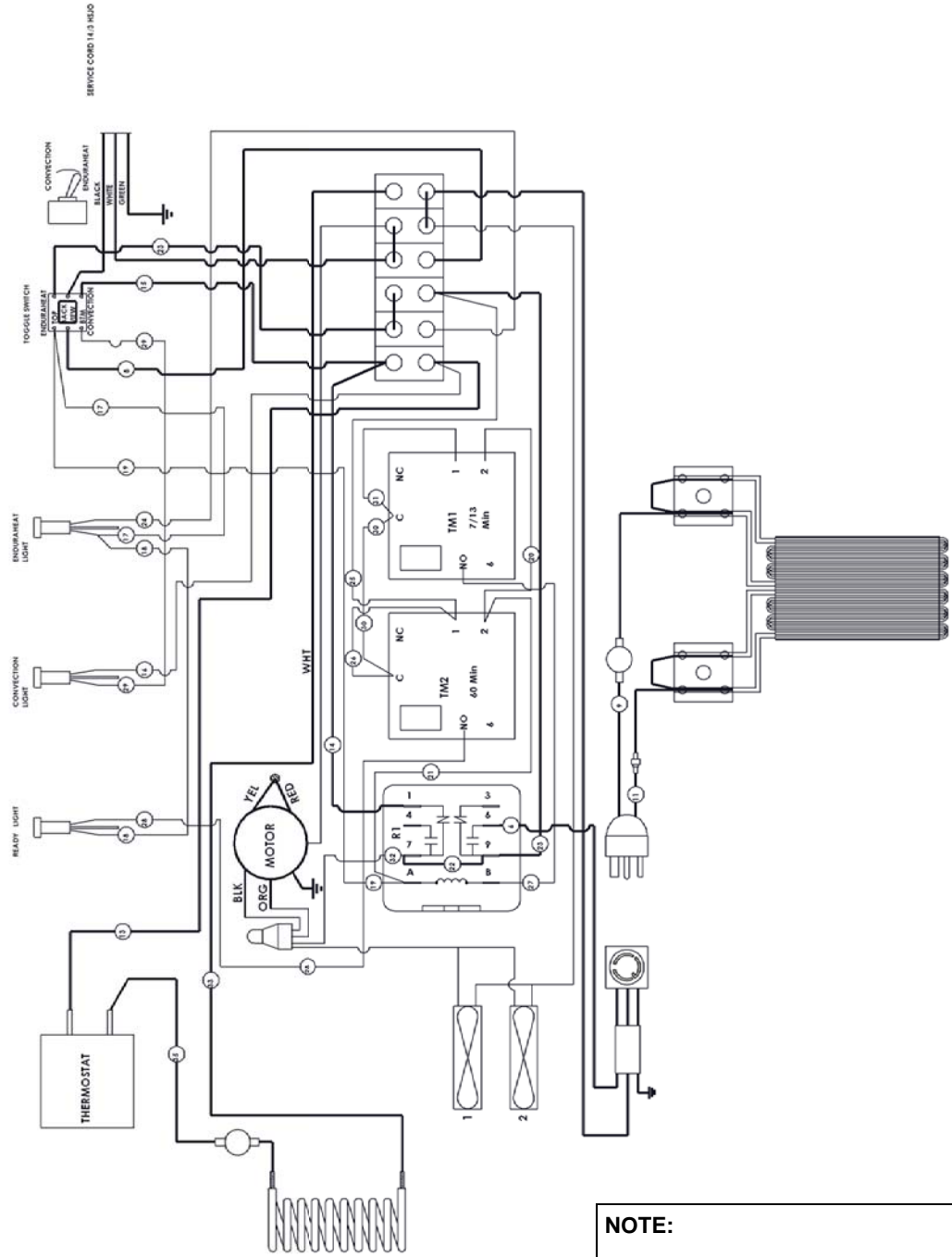

NOTE:
 The technical content of this manual, including wiring diagrams, schematics, parts breakdown illustrations and/or adjustment procedures, is **intended for use ONLY by qualified technical personnel.**

REPLACEMENT PARTS

Use only (OEM) original equipment manufacturer replacement parts. Using unauthorized parts may cause serious injury or damage to the cabinet. Replacement parts should be installed by a qualified service technician.

Contact Carter-Hoffmann with your model and serial number for replacement parts.

Call: 800-323-9793 or
Email: Service@Carter-Hoffmann.com

Part Number	Description
Top Convection Heater	
18600-0046	Hi limit—open at 300°F, close at 250°F
18602-0238	Time relay—recycler
18602-0239	Time relay-delay on make
18602-0240	Relay
18605-0017	14/3 HJSO cord w/ 5-20 plug
18607-0010	Terminal block—6 POS #306
18612-0096	Box element-120 volt, 1500 watt
18614-0316	Blower housing #C1281-1
18614-0316	Cord set x 40", #4C552
18614-0321	Blower wheel
18614-0322	Muffin fan
18614-0360	Convection motor-120/208/220/230/240
18602-0016	Toggle switch
18602-0031	Rubber switch boot
18601-1176	Convection heat indicator light (white)
EnduraHeat Module	
18605-0027	14/3 cord/L5-20P assembly
18606-0563	Twist lock 20A, 125v receptacle
18610-0010	Handy box: 2x4 4SSL-1/2
18610-0110	Cover plate
18610-0198	3/8" lock nut
18617-0007	Cord grip
18617-0054	Ceramic terminal block
18612-0116	Tubular element, 120v
18612-0347	Heat retention module
18600-0061	Thermostat-225 deg./25A
18601-1176	EnduraHeat indicator light (white)
18601-1175	Enduraheat ready light (green)
Cabinet Parts	
18303-0085	Door handle

TROUBLESHOOTING GUIDE

PROBLEM	PROBABLE CAUSE	POSSIBLE REMEDY
No power to unit, No light on display Motor not running	Not plugged in or circuit breaker off or tripped	Plug into receptacle. Reset circuit breaker, check facility circuit breaker
	Main switch damaged	Check main power switch, replace if damaged
	Damaged power cord	Replace cord
	Hi-limit safety tripped	Allow unit to cool, hi-limit will reset automatically, or replace
Unit does not hold temperature	Damaged door gasket (metal trim strip)	Replace gasket
	Damaged door latch	Replace defective latch
	Temp probe damaged	Replace probe
	Door gap, out of alignment	Adjust door hinging and strike
Unit does not heat	Cabinet temp above setpoint (setpoint too low)	Turn thermostat setpoint up Check thermometer calibration
	Internal wiring error	Call service technician
	Damaged relay	Call service technician
	Damaged controller	Call service technician
	Damaged heating element	Perform ohm reading, Replace element
Unit overheats	Setpoint too high	Change setpoint
	Thermostat damaged	Replace thermostat
	Defective hi-limit control	Call service technician
	Blower fan failure	Call service technician
Blower motor not running	Damaged fan motor	Replace motor
	Blower fan jammed	Find source of fan binding
Relay is "chattering"	Check proper wiring to switch	Repair wiring or replace switch
Takes too long to get to temperature	Improper voltage	Call service technician to verify that incoming voltage matches cabinet specifications

NOTE:

The technical content of this manual, including wiring diagrams, schematics, parts breakdown illustrations and/or adjustment procedures, is **intended for use ONLY by qualified technical personnel.**

NOTE:

For warranty service, call Carter-Hoffmann direct at 800-323-9793 for authorization. We will dispatch the nearest authorized service agency.

SERVICE EXPECTATIONS

Service Philosophy

For almost sixty years, Carter-Hoffmann has enjoyed a reputation for manufacturing rugged, dependable foodservice equipment that permits foodservice professionals serve more food products to more people, and thus, to grow their business.

Our goal is not only to provide the best food service equipment for the price, but also to back it up with after-sale service that is responsive, fast, efficient and professional. To ensure a clear understanding of our goals, expectations, and responsibilities, we have prepared this brief document.

Carter-Hoffmann products are innovative and efficient. They are easy to use, easy to clean and easy to maintain. Although the products are quite reliable they are also designed for easy repair. We believe that a malfunction to a Carter-Hoffmann product should cause as little inconvenience to the customer as possible. Our aim is to provide "same day/first time fix" repair service on all of our products. We are dedicated to making every aspect of our customer service the standard by which others are judged.

End-User Responsibilities

While we all strive to serve our mutual customers as well as possible that does not mean that the end-user (including his employees) does not share some responsibilities.

1. All shipping damage must be noted on the freight bill when the shipment is received. Any freight damages must be collected from the Freight Company, NOT Carter-Hoffmann.
2. The end-user should be advised beforehand to carefully unpack and inspect all products when they are received BEFORE SIGNING THE SHIPPER'S RECEIPT OF DELIVERY.
3. The end-user must provide a safe, dry, level surface for the equipment to be placed upon.
4. The end-user must provide the proper electrical supply. All in-wall electrical modifications are to be completed by a licensed electrician. All building modifications are the responsibility of the end-user.
5. The end-user must operate, clean and maintain the equipment in accordance with the procedures described in the Operation Manual.
6. Carter-Hoffmann is NOT responsible for any loss of the customer's income, loss of food product, extra labor charges, or any other incidental or consequential costs as a result of the malfunction of our product.
7. The end-user shall allow for on-premises repair of the equipment to be completed at a mutually convenient place and time.

Warranty Service

1. Warranty service is to be **initiated** by authorized Carter-Hoffmann personnel only.
2. The service provider is **NOT** authorized to change or extend any of the terms or conditions of our warranty.
3. Initial freight damage is **NOT** covered by the product warranty.

Confidentiality

1. The end user and all his employees and sub-agents shall protect and keep confidential Carter-Hoffmann's proprietary designs, information, and knowledge.
2. All literature and informational materials provided by Carter-Hoffmann are to be considered confidential; they remain Carter-Hoffmann's property; and are not to be reproduced without our prior written consent.

OWNER INFORMATION

YOUR LOCAL CONTACTS

SERVICE & PARTS DISTRIBUTOR FACTORY SALES REPRESENTATIVE

NAME:
CONTACT:
ADDRESS:

TEL:
FAX:
TOLL FREE:

EMAIL:

WEBSITE:

SERVICE LOG

DATE	SERVICE AGENT	NATURE OF PROBLEM / ACTION TAKEN
------	---------------	----------------------------------

IMPORTANT OWNER INFORMATION

Please take the time to record the model number and serial number, the identification decal is normally located on the right hand side of the unit. Also be sure to record your voltage and purchase date of your piece of Carter-Hoffmann equipment in the spaces below.

It is extremely helpful to have this information available when calling Carter-Hoffmann for service or assistance.

Cabinet Model #: _____

Cabinet Serial #: _____

Heater Head Model #: _____

Heater Head Serial #: _____

Voltage: _____

Wattage: _____

Phase: _____

Date of Installation: ____/____/____

Carter-Hoffmann Invoice / Sales Order #: _____

Purchase Order #: _____

WARRANTY

Carter-Hoffmann Warranty:

Carter-Hoffmann ("CARTER-HOFFMANN") warrants to the initial purchaser of its standard Carter Line Products that CARTER-HOFFMANN will, at its option, repair or replace, during the warranty period set forth below, any part of such products made necessary due to a defect in material or workmanship which is present when the product leaves its factory and which manifests itself during the warranty period under normal use and service.

*This warranty applies only to original equipment owned and possessed by the initial purchaser and the warranty period begins on the date of original shipment from the CARTER-HOFFMANN factory and extends as follows: **to component parts and labor for 12 months; to refrigeration compressor unit for one year** (limited to replacement only - not to include labor for removal, repair or replacement).*

Repair or replacements under this warranty will be performed, unless otherwise authorized in writing by CARTER-HOFFMANN, at its factory. All parts or components to be repaired or replaced under this warranty are to be shipped prepaid to CARTER-HOFFMANN, with reimbursement credit for such part or component to be given if found by CARTER-HOFFMANN to be defective.

CARTER-HOFFMANN neither makes nor assumes and does not authorize any other person to make or assume any obligation or liability in connection with its products other than that covered in this warranty. This warranty applies only within the continental United States and Canada. In Alaska and Hawaii, this warranty applies only to and is limited to the supply of replacement parts.

Warranty Exclusions and Limitations:

Any implied warranty of merchantability or fitness for a particular purpose is hereby specifically disclaimed by CARTER-HOFFMANN. There are no warranties, expressed or implied, which extend beyond the description on the face hereof. This warranty does not cover and CARTER-HOFFMANN shall not under any circumstances be liable for any incidental, consequential or other damages (such as injury to persons or property, loss of time, inconvenience, loss of business or profits, or other matters not specifically covered) arising in connection with the use of, inability to use, or failure of these products.

Specifications subject to change through product improvement and innovation.

Carter-Hoffmann

1551 McCormick Ave.

Mundelein, Illinois, 60060 USA

Phone: 847-362-5500 Toll free: 800-323-9793 Fax: 847-367-8981

Sales and Marketing E-mail: sales@carter-hoffmann.com

Service E-mail: service@carter-hoffmann.com

Company Website: www.carter-hoffmann.com

CFESA

Proud Member

NAFEM
North American Association of
Food Equipment Manufacturers